

H&R

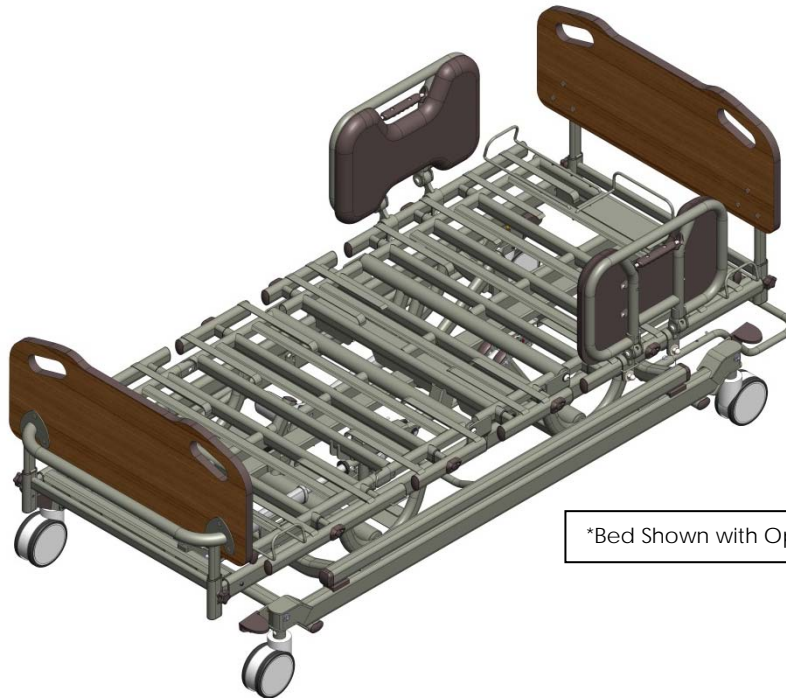

Bariatric 1000 Full Electric
Long Term Care Bed
Model # P2002
Owner's Manual



*Bed Shown with Optional Head/Foot Boards

This manual must be given to the Owner/User of this bed and should be read carefully before putting this product into use. Keep manual in an accessible location for future reference.

Drive Medical Design & Manufacturing
99 Seaview Blvd
Port Washington, NY 11050
Phone: 1.877.224.0946
Fax: 516.988.4601
www.drivemedical.com

TABLE OF CONTENTS

STANDARD SYMBOLS USED IN THIS MANUAL	2
WARNING LABELS	3
INTENDED USE	4
CONTRA-INDICATIONS.....	4
GENERAL SAFETY	4
LEFT/RIGHT REFERENCE GRAPHIC	9
ELECTROMAGNETIC EMISSION AND IMMUNITY	10
FEATURES AND ACCESSORIES	13
TECHNICAL SPECIFICATIONS.....	14
COMPLIANCE INFORMATION	15
ASSEMBLY	16
FREQUENTLY USED BED FUNCTIONS	27
BED MOBILIZATION AND STABILIZATION.....	29
CARE AND MAINTENANCE	30
INSPECTIONS	31
SERVICING	33
TROUBLESHOOTING GUIDE	35
WARRANTY.....	37
END OF LIFE DISPOSAL.....	38
APPENDIX	39

NOTE: DO NOT operate this product without first reading and understanding this user manual. Damage or injury may result from improper use of this product.

STANDARD SYMBOLS USED IN THIS MANUAL

This manual includes important information about the safety of personnel and equipment. As you read through this manual be aware of the symbols and their meanings.



DANGER

Information that appears under the DANGER symbol concerns the protection of personnel from direct and pending hazards that, if not avoided, will result in immediate, serious personal injury or death in addition to damage of the equipment.



DANGER SHOCK HAZARD

Information that appears under the DANGER SHOCK HAZARD symbol concerns the protection of personnel from possible hazards related to electrical shock.



FIRE HAZARD

Information that appears under the FIRE HAZARD symbol concerns the protection of personnel from possible hazards related to fire and flammability.



WARNING

Information that appears under the WARNING symbol concerns the protection of personnel from possible hazards that can result in injury or death in addition to damage of the equipment.



CAUTION

Information that appears under the CAUTION symbol concerns the protection of personnel from possible hazards that may result in minor injury or damage of the equipment.



CRUSH HAZARD

Information that appears under the CRUSH HAZARD symbol concerns the protection of personnel from possible hazards related to reduced clearances.

NOTE:

Information that appears under the NOTE text gives added information, which helps in understanding the item being described.

PRODUCT SYMBOLS

Symbols	Description	Symbols	Description
	According to IEC 60417-5840. Type B applied part equipment		Change head deck position
IP54	According to IEC 60529. Rating for dust-protection and identified as equipment that is protected against splashing water.		Change thigh/foot deck position
	According to ISO 7000-1641. Operating instructions		Change auto-contour position
	Recycle the item in accordance with local regulations.		Change hi-lo position of mattress support platform
	Intertek's ETL listed mark for US and Canada. A product bearing the ETL listed Mark is determined to have met the minimum requirements of prescribed product safety standards.		Change Reverse Trendelenburg angle
CE	CE mark		Change Trendelenburg angle
	Class II equipment		Safe Working Load
	Maximum Patient Weight		Up
	Warning symbol		Down
	Danger: electricity, electrical hazard symbol		Flammable material symbol
	Warning crushing of hands		Warning crushing of feet

WARNING LABELS

 WARNING	<p>Incompatible SIDE RAILS can create hazards. READ INSTRUCTIONS FOR USE.</p> <p>SIDE RAILS incompatibles peuvent créer risques. LISEZ LES INSTRUCTIONS D'UTILISATION.</p> <p style="text-align: right;">P/N:TU60000006E REV:000</p>
 WARNING	<p>Incompatible MATTRESSES can create hazards. READ INSTRUCTIONS FOR USE.</p> <p>MATELAS incompatibles peuvent créer risques. LISEZ LES INSTRUCTIONS D'UTILISATION.</p> <p style="text-align: right;">P/N:TU60000007E REV:000</p>

INTENDED USE

This Primus Medical by Drive Bariatric bed is intended for use within an institutional healthcare environment, Application Environment 3 (i.e.: Skilled Nursing, Transitional Care, Rehabilitation Care, Assisted Living).

Compliance with the regulations and guidelines as specified by your facility is recommended.

This bed is **NOT** intended for patient/resident transport. Wheels are provided only to allow movement within the patient/resident room for cleaning or patient/resident access.

CONTRA-INDICATIONS

This bed should not be used by persons who do not have the cognitive skills to understand the information in the owner's manual, operate the bed or control the movements of the bed through the control interfaces. This bed should not be used or operated by children.

GENERAL SAFETY

NOTE: *In this manual, the terms patient and resident refer to a resident of a Nursing Home, Long Term Care, Assisted Living or Rehabilitation facility.*



DANGER

- **NEVER** allow anyone under the bed at any time.
- **DO NOT** let any body parts protrude over the side or between parts, especially when the bed is being operated.



DANGER SHOCK HAZARD

- **DO NOT** plug anything into the control box of bed (i.e. pendants and actuators) while mains cable (power cord) is plugged into the wall outlet.
- Any cords or tubing used on or with this bed **MUST** be routed and secured properly to ensure they do **NOT** become entangled, kinked or severed during normal operation of the bed.
- **DO NOT** roll the bed over any power or pendant cords.



DANGER SHOCK HAZARD

- This bed is equipped with a three-prong grounding plug for protection against possible shock hazard. DO NOT under any circumstances cut or remove the grounding prong.
- DO NOT open any actuators, control boxes or pendants. Service is only to be performed by authorized service personnel. If unauthorized service is performed on any components the warranty is void.
- Inappropriate handling of power supply cords can create a shock hazard.
- When routing cables from other equipment in the medical bed, precautions shall be taken to avoid squeezing those between parts of the medical bed.
- DO NOT use an extension cord.
- DO NOT allow the cord, electrical outlets, and electrical control box or hand pendant to become wet or submerged.
- DO NOT operate the bed if any electrical component such as the power cord, electrical outlet, connections, motor/actuator or mechanical component has malfunctioned or has been damaged in any way.
- To avoid risk of electric shock, this equipment must only be connected to a supply mains with protective earth.



FIRE HAZARD

- DO NOT use near open flame or explosive gases.
- Possible Fire Hazard if used with nasal mask in 1/2 bed tent O₂ administering equipment. If O₂ tent is being used it should not fall below the mattress deck. The pendant should not be placed in an oxygen enriched environment such as an O₂ tent.
- This bed should not be placed in an oxygen enriched environment.



WARNING

- DO **NOT** operate this product without first reading and understanding this user manual. Damage or injury may result from improper use of this product.
- Possible injury or Death may occur if accessories are not provided by Primus Medical by Drive. Please contact Primus Medical by Drive for accessories that are compatible with this bed.
- Possible injury or Death may occur if replacement parts are not provided by Primus Medical by Drive. Please contact Primus Medical by Drive for replacement parts compatible with this bed.
- Possible injury or Death may occur due to pendant cord being a source for entangling patient/resident. Patients/residents with decreased mental acuity should NOT have access to pendant.
- Unplug bed or stop pressing pendant button when bed does not function as expected.

- NEVER permit more than one (1) person in/on the bed at any time. NEVER exceed the weight capacity of this bed. The weight capacity of this bed is **1000lbs (453kg) including accessories and options (not all accessories and options can be used at the same time).**

Assumes:	Max Patient/Resident Weight	756lbs (343 kg)
	Assist Rail (pair)	35lbs (16kg)
	Assist Rail (4)	70lbs (32kg)
	Head/Foot Board	41lbs (18.5kg)
	Pendant	1.1lbs (0.5kg)
	Mattress weight	55lbs (25kg)
	Trapeze	75 lbs (34kg)

- The medical bed should be left in its lowest position except when care is being provided in order to reduce risk of injury due to falls.
- The bed **MUST** be connected to an appropriate power source. Unless equipped with the optional battery backup, this bed will not operate when not plugged in. Mains cable and proper function must be checked regularly.
- Possible Injury or Death may occur if bed is pushed over abrupt thresholds while bed is occupied. **This bed is not intended for patient/resident transport.** Please use an approved resident transport device when moving a resident

**CAUTION**

- This medical bed is not intended to work with patient lifts other than those specified by Primus Medical by Drive as being compatible.
- Do **NOT** use assist rails as handles for moving the bed.
- Keep all moving parts; including the mattress deck (sleep surface), main frame, all drive actuators and moving components free of obstructions.
- Ensure that the individual using this bed is properly positioned, particularly when the bed is being operated.
- Body weight should be evenly distributed over the sleeping surface of the bed. Avoid situations where entire body weight is on a raised head or foot surface. This includes while assisting the resident in repositioning or transferring in or out of bed.
- NEVER allow anyone under the bed at any time.
- Supervision is required when this product is operated by or near children or people with disabilities.
- DO NOT let any limbs or body parts protrude over the side or between bed components, especially when the bed is being moved or operated.
- Caster locks shall be used except when bed is being moved. **Bed is not intended for patient/resident transport.**
- Bed should be at lowest suitable height for entry and exit.
- Assembly of this bed and modifications made during the actual service life require evaluation to comply with the requirements of IEC 60601-1 and IEC 60601-2-52. No modification of this equipment is allowed.
- Only items that have been specified as part of this bed or that have been specified as being compatible with this bed shall be connected to it.
- This bed frame complies with EMC requirements of IEC 60601-1-2. Radio transmitting equipment, cell phones or similar electronic devices, used in proximity of the bed, may affect the beds performance.

**ENTRAPMENT WARNING**

Accurate assessment of the resident and monitoring of correct maintenance and equipment use are required to prevent entrapment. For additional information on product and safety issues for bed frames and rails refer to product manuals specific to the product or accessories you have or are planning to install. If bed frames have been serviced or any other adjustments have been made, you must ensure all parts are securely back in place before operating the bed. Other manufacturers assist rails may not be compatible and can lead to entrapment issues or harm to residents and staff. Make sure mattress is the correct size for bed frame and the assist rails are secured to frame to decrease the risk of entrapment.

On March 10, 2006, the U.S. Food and Drug Administration (FDA) released guidelines for reducing the risk of hospital bed entrapment entitled; "Hospital bed System Dimensional and Assessment Guidance to Reduce Entrapment". This guidance document identifies potential entrapment areas within the bed frame, rails and mattress and identifies those body parts most at risk for entrapment. It also provides manufacturers with basic design criteria to consider when developing hospital/convalescent beds; recommends specific test methods to assess the conformance of existing hospital/convalescent bed systems; and answers frequently-asked questions about entrapment issues.

The FDA Guidance document identifies specific dimensional criteria on potentially injury-threatening gaps and spaces that can occur between bed system components, such as side rails when improperly installed. Drive Medical's Long Term Care beds and approved accessories are manufactured to be in conformance with these guidelines.

Please be aware that entrapment issues can still arise when components and accessories are not properly installed on the bed. It is important for the provider or facility staff to recognize they have an equal role in complying with the FDA guidelines to help ensure resident safety and avoid injuries.

Copies of this document can be obtained from the FDA website:

<http://www.fda.gov/medicaldevices/deviceregulationandguidance/guidancedocuments/ucm072662.htm>

**ASSIST RAIL WARNING**

Other manufacturers assist rails may not be compatible and can lead to entrapment issues or harm to patients/residents. Only compatible Primus Medical by Drive assist rails may be used on this bed. Ensure mattress is the correct size for bed frame and the assist rails are secured to frame to decrease the risk of entrapment.

MATTRESS SPECIFICATIONS



WARNING

Possible ENTRAPMENT Hazard may occur if you do not use the recommended specification mattress.

Resident entrapment may occur leading to injury or death.

A mattress may not be included with this bed. Mattresses sized to the dimensions of the mattress support platform must be used.

See Technical Specifications page for compatible mattress dimensions.

EMERGENCY EVACUATION

- If your mattress has Velcro side bolsters remove them and adjust mattress retainers inward.
- Push in extension buttons and slide extensions inward towards the center of the bed and remove the side mattress retainers.
- It may be necessary to remove assist rails to fit through your doorways.
- Perform this procedure on both sides of the bed.
- The bed is now at 39" wide and can be used to evacuate Resident out of the facility. This bed is **NOT** intended to be used for resident transport.

LEFT/RIGHT REFERENCE GRAPHIC

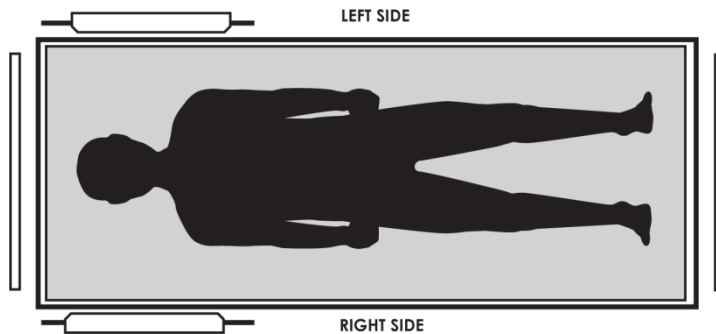

ELECTROMAGNETIC EMISSION AND IMMUNITY

This MEDICAL ELECTRICAL EQUIPMENT needs special precautions regarding EMC and needs to be installed and put into service according to the EMC information provided in the table below.

Portable and mobile RF communications equipment can affect MEDICAL ELECTRICAL EQUIPMENT



WARNING

The use of ACCESSORIES, transducers and cables other than those specified, with the exception of transducers and cables sold by the manufacturer of the EQUIPMENT or SYSTEM as replacement parts for internal components, may result in increased EMISSION or decreased IMMUNITY of the EQUIPMENT or SYSTEM.

DECLARATION - ELECTROMAGNETIC EMISSIONS

Guidance and manufacturer's declaration - Electromagnetic emissions		
The PrimePlus™P2002 is intended for use in the electromagnetic environment specified below. The customer or the user of the PrimePlus™P2002 should ensure that it is used in such an environment.		
Emissions Test	Compliance	Electromagnetic environment - Guidance
RF Emissions CISPR 11	Group 1	The PrimePlus™P2002 must emit electromagnetic energy in order to perform its intended function. Nearby electronic equipment may be affected.
RF Emissions CISPR 11	Class B	The PrimePlus™P2002 is suitable for use in all establishments including domestic establishments and those directly connected to the public power supply network that supplies buildings used for domestic purposes.
Harmonic Emissions IEC 61000-3-2	Not Applicable	
Voltage fluctuations/ flicker emissions IEC 6100-3-3		

Recommended separation distances between portable and mobile RF communications equipment and the PrimePlus™P2002			
The PrimePlus™P2002 is intended for use in the electromagnetic environment in which radiated RF disturbances are controlled. The customer or the user of the PrimePlus™P2002 can help prevent electromagnetic interference by maintaining a minimum distance between portable and mobile RF communications equipment (transmitters) and the PrimePlus™P2002 as recommended below, according to the maximum output power of the communications equipment.			
Rated maximum output power of transmitter W	Separation distance according to frequency of transmitter m		
	150 kHz to 80 MHz $d = (1,2\sqrt{P})$	80 MHz to 800 MHz $d = (1,2\sqrt{P})$	800 MHz to 2,5 GHz $d = (2,3\sqrt{P})$
0.01	0.12	0.12	0.23
0.1	0.38	0.38	0.73
1	1.2	1.2	2.3
0.1	0.38	0.38	0.73
10	3.8	3.8	7.3
100	12	12	23
For transmitters rated at a maximum output power not listed above, the recommended separation distance d in meters (m) can be estimated using the equation applicable to the frequency of the transmitter, where P is the maximum output power rating of the transmitter in watts (W) accordable to the transmitter manufacturer.			
NOTE: 1 At 80 MHz and 800 MHz the separation distance for the higher frequency range applies			
NOTE: 2 These guidelines may not apply in all situations. Electromagnetic propagation is affected by absorption and reflection from structures, objects and people.			

Guidance and manufacturer's declaration: Electromagnetic Immunity			
The PrimePlus™P2002 is intended for use in the electromagnetic environment specified below. The customer or the user of the PrimePlus™P2002 should ensure that it is used in such an environment.			
Immunity test	IEC 60601 test level	Compliance level	Electromagnetic environment - guidance
Conducted RF IEC 61000-4-6 Radiated RF IEC 61000-4-3	3 Vrms 150 kHz to 80 MHz 3 V/m 80 MHz to 2.5 GHz	3 Vrms 3 V/m	<p>Portable and mobile RF communications equipment should be used no closer to any part of the PrimePlus™P2002 including cables, than the recommended separation distance calculated from the equation applicable to the frequency of the transmitter.</p> <p>Recommended separation distance</p> $d = (1,2\sqrt{P})$ $d = (1,2\sqrt{P})80\text{MHz to } 800\text{MHz}$ $d = (1,2\sqrt{P})800\text{MHz to } 2,5\text{MHz}$ <p>Where P is the maximum output power rating of the transmitter in watts (W) according to the Transmitter manufacturer and d is the recommended separation distance in meters (m). Field strengths from fixed RF transmitters, as determined by an electromagnetic site survey,^a should be less than the compliance level in each frequency range.^b</p> <p>Interference may occur in the vicinity of equipment marked with the following symbol:</p> 
<p>NOTE: 1 At 80MHz and 800MHz the higher frequency range applies.</p> <p>NOTE: 2 These guidelines may not apply in all situations. Electromagnetic propagation is affected by absorption and reflection from structures, objects and people.</p>			
<p>^a Field strengths from fixed transmitters, such as base stations for radio (cellular/cordless) telephones and land mobile radios, amateur radio, AM and FM radio broadcast and TV broadcast cannot be predicted theoretically with accuracy. To assess the electromagnetic environment due to fixed RF transmitters, an electromagnetic site survey should be considered. If the measured field strength in the location in which the PrimePlus™P2002 is used exceeds the applicable RF compliance level above, the PrimePlus™P2002 should be observed to verify normal operation. If abnormal performance is observed, additional measures may be necessary, such as reorienting or relocating the PrimePlus™P2002.</p> <p>^b Over the frequency range 150 kHz to 80 MHz, field strengths should be less than $[V_i]$ V/m.</p>			

FEATURES AND ACCESSORIES

Standard Features

Travel Range: 19.1"-31.7"

Width Extension: 37", 39", 42", 48", 54"

Locking System: 5" Locking Casters

Left and Right side Pendant Connections

Slat Deck

Heavy Duty Casters

Mattress Retainers

Soft Gray Powder Coated Frame Color

Wall Guard

Assist Rails**

80", 84", 88" Sleep Surface

Bed End Panels

Accessories and Options

Pressure Reduction or Low-Air-Loss

Mattress

Extra Padded Assist Rails**

Fall Mat

Battery Back-Up

Trapeze (Free Standing or Bed Mounted)

Staff control panel

Built In Weigh Scale



WARNING

***Incompatible assist rails can create hazards. Read instructions for use. Use only assist rails that Primus Medical by Drive has indicated are compatible with this bed.*

Bed Serial Numbers

When ordering parts or when contacting Drive Customer Service Department, please include bed's model and serial numbers, found on the identification labels. The identification labels are located under the sleep deck on the frame rail below the mattress support platform on either side of the bed.

TECHNICAL SPECIFICATIONS

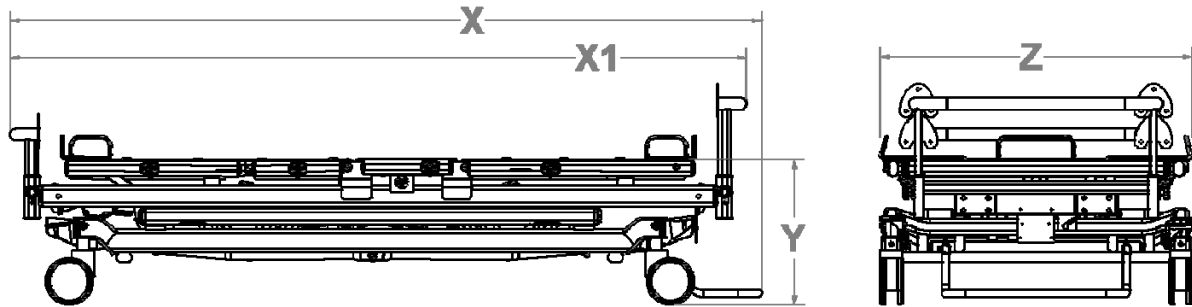

ITEM	Imperial	Metric
Overall Length, 80" position with wall guard. (X)	100"	254cm
Overall Length, 80" configuration (X1) (with head & foot boards; no wall guard)	92"	234cm
Overall Width – mobility position** (Z)	38.2"	97.1cm
Mattress deck width with extension to 1 st pins	37"	94 cm
Mattress deck width with extension to 2 nd pins	39"	99 cm
Mattress deck width with extension to 3 rd pins	42"	107 cm
Mattress deck width with extension to 4 th pins	48"	122 cm
Mattress deck width with extension to 5 th pins	54"	137cm
Length of mattress deck	80" , 84" , 88"	203, 213, 223 cm
Mattress deck height (low position) (Y)	19.1"	48.5 cm
Mattress deck height (high position) (Y)	31.7"	80.5cm
Head deck angle range	0° to 68°±3°	
Thigh deck angle range	0° to 38°±3°	
Foot deck angle range	0° to 22°±3°	
Trendelenburg/Reverse Trendelenburg capable	Yes	
Mattress length (80" mattress deck length)	80"	203 cm
Mattress length (84" mattress deck length)	84"	213 cm
Mattress length (88" mattress deck length)	88"	223 cm
Mattress thickness range	5 ½" – 8"	14 – 20 cm
Pendant connections on both sides of bed	Yes	
Weight of bed**	469lbs	213 Kg
Safe Working Load***	1000lbs	453 Kg
Maximum User weight	756lbs	343 Kg
Input Voltage****	100-240VAC , 50/60 Hz	
Actuator Voltage	24 VDC	
Protective Earth Ground	CLASS II	
Electrical Shock Protection	TYPE B	
Enclosure Protection	IP54	
Duty Cycle	Max.2min(ON), Min.18min (OFF)	

**Without mattress or assist rails – assist rails add 2.7 inches to width of bed

***SWL includes the weight of the resident/patient and all other accessories including, but not limited to mattresses, head/foot boards, assist rails, etc.

******Means of isolating equipment from supply mains:**

This bed is isolated from the supply mains by unplugging the mains plug from the wall outlet.

COMPLIANCE INFORMATION

Matching the correct bed components to meet regulatory specifications can be complicated. Primus Medical by Drive offers a wide variety of compliance options. Primus Medical by Drive can assist your facility in selecting components or accessories that are recommended for the specific bed model.

General information

The recommended environment for operation and storage / transportation of the bed is listed below:

	Operation	Storage/Transportation
Ambient temperature:	10°C ~ 40°C (50°F~104°F)	-10°C ~ 50°C (14°F~122°F)
Relative humidity range:	30% ~ 75%	30% ~ 75%
Atmospheric pressure:	86KPa~ 106Kpa	86KPa~ 106KPa

This bed is classified for intermittent operation. Bed actuators may be operated for 2 minutes out of every 20 minutes.

Applied Parts List

- Bed Frame
- Head/ Foot Board
- Assist Rails
- Mattress Retainer
- Width Extension
- Pendant
- Trapeze

Materials accessible to user

- Surface Coating: Powder Coating
- Color of Powder: Carbon black, Ethylene Bis-Stearamide, Solvent Red
- Pendant Housing: PA-765A
- Rail release handle: ABS
- Head/Foot Board: Wood
- Trapeze: PVC, steel, nylon webbing

UNPACKING INSTRUCTIONS

TOOLS REQUIRED

• Pliers or Wire Cutters	• Utility Knife
--------------------------	-----------------



CAUTION

DAMAGE to the equipment may occur if the zip ties are removed incorrectly.

- Package should be received on a pallet covered by a box.

- It may be necessary for two or more people to remove the bed from the pallet.
- After the bed is removed from the pallet, locate the box containing the assist rails.
- Remove the mattress retainers from the bed frame. They are wrapped in foam and zip tied to the frame.
- Remove any remaining zip ties or foam left on bed frame.
- Make sure all connections to the control box are secure
- The product should be positioned in a way that the mains plug is easily plugged into and unplugged from a wall outlet

NOTE: *DO NOT remove zip ties that are holding cords underneath bed frame.*

INITIAL INSPECTION

- Inspection of All Components – Receipt of assembled bed
- Check bed components for obvious damage.
- Inspect power supply cords for cuts and/or damage
- If power cord is free of damage, plug into grounded 100-240 VAC outlet
- Check that actuator cords are connected properly to the controller.
- Raise the bed frame and check to ensure all cables are plugged securely into the control box and no wires are loose.
- Verify proper functionality of all features **AFTER ASSEMBLY**.

ASSEMBLY

TOOLS REQUIRED

• ¾" Wrench and Socket	• 5/32" Hex Key
• 5/16" Hex Key	• (2) 3/16" Hex Key

KNOWLEDGE/SKILLS REQUIRED

• Ability to read and understand owner's manual	• Ability to manipulate required tools
• Basic mechanical aptitude	

MATTRESS RETAINER INSTALLATION/ADJUSTMENT

Mattress retainers are designed to keep the mattress in place on the sleep surface.

- Determine size of your mattress
- There are two different sizes of mattress retainers. 4 narrow retainers for the sides of the bed and 2 wider retainers for the end of the bed.
- Insert the two end mattress retainers in the holes appropriate for the length mattress being used. Length options are detailed in the technical specification section.



- Install the mattress retainers into 4 locations on the sides of the bed in the appropriate holes for the width mattress being used. Width options are detailed in the technical specification section.



HEADBOARD AND FOOTBOARD INSTALLATION AND ADJUSTMENT

TOOLS REQUIRED

<ul style="list-style-type: none"> • 3/16" Hex Key (2) 	
---	--

- Using a 3/16 hex key, bolt the head and foot board to the mounting brackets.



- Unscrew knobs on each side of support assembly at both ends of the bed frame.



- Place the headboard/footboard mounting brackets into the slots of the bed frame support assembly.

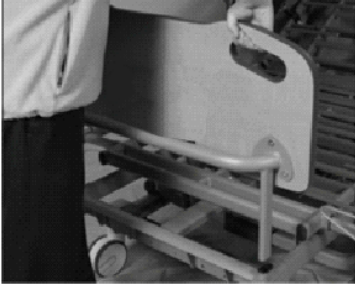

NOTE: *The mounting bracket on the foot board should have the push/pull bar facing away from the bed.*

- Slide headboard/footboard down until it stops.



- Screw the knobs back in on each side of the support assembly to lock the headboard/footboard in position.



- If the P2002 Bed is ordered with the OPTIONAL Embedded Staff Control/footboard control panel. Locate the end of the footboard control cable and plug it into the end of the extension cable located in central frame channel. Close the locking hood over the connection point.

ASSIST RAIL ASSEMBLY

TOOLS REQUIRED

<ul style="list-style-type: none"> • ¾" Wrench 	<ul style="list-style-type: none"> • ¾" Socket
<ul style="list-style-type: none"> • 5/16" Hex Key 	<ul style="list-style-type: none"> • 5/32" Hex Key

Remove the protective paper that is around the assist rail pads by removing the (4) bolts on the back of the assist rail pads using 5/32" hex key. Remove the paper and place the bolts back onto the assist rail pads. Do this for both assist rails. The assist rails are now ready to be assembled on the bed frame.

- Place assist rail on side of bed sliding one bracket into the locating bale making sure the other bracket goes over the locating sticker.

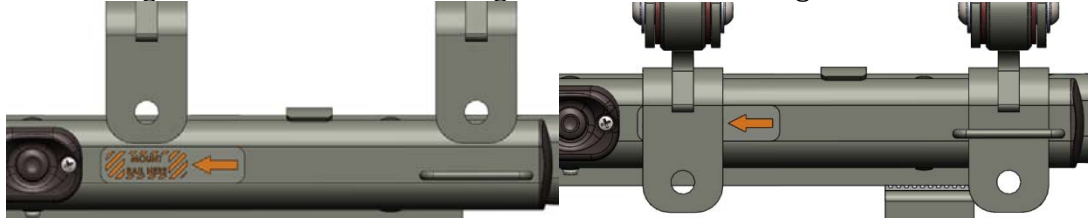

- The holes on the bracket of the assist rail should be below mattress deck.
- Slide a washer onto a ½" bolt and insert the bolt as shown.
- Place a second washer on the bolt on the back of the assist bracket.
- Place acorn nut over the end of the bolt.
- Use a ¾" Wrench and Socket to tighten the bolt.
- Repeat the previous step for the remaining bolts for the assist rails.
- ASSIST RAILS WILL CAUSE DAMAGE TO BED IF NOT INSTALLED CORRECTLY

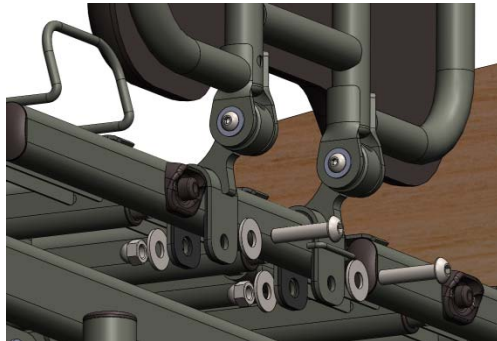

NOTE: *It is normal to have some play in the assist rail.*



ASSIST RAIL WARNING

Other manufacturers assist rails may not be compatible and can lead to entrapment issues or harm to patients/residents. Only compatible Primus Medical by Drive assist rails may be used on this bed. Make sure bed frame is adjusted correctly for mattress size being used and assist rails are properly secured to frame to decrease the risk of entrapment.



ENTRAPMENT WARNING

The risks associated with these devices used in conjunction with specialty mattresses and mattress overlays have not been evaluated. When these specialty mattresses or mattress overlays are used, the end user facility must take steps to ensure that the therapeutic benefit outweighs the risk of entrapment.



ASSIST RAIL WARNING

Assist rails are intended only to assist the resident during bed entry and exit. These devices are not side rails nor are they intended to be used in a manner that makes user entry or exit more difficult.

WIDTH EXTENSION (No tools needed)

Choose which width the bed needs to be expanded to. This bed has 4 width settings: 37" (mobility position only), 39", 42" and 48".

The width extension expands by using the push button mechanism.

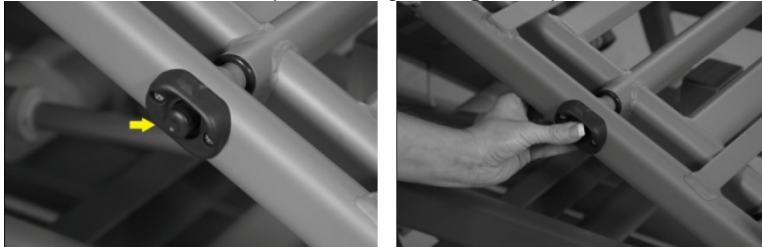

- Push the expansion button mechanism in and pull out width extension until you reach the desired width of the bed deck.
- Position the side mattress retainers in the appropriate holes for the Mattress width chosen.

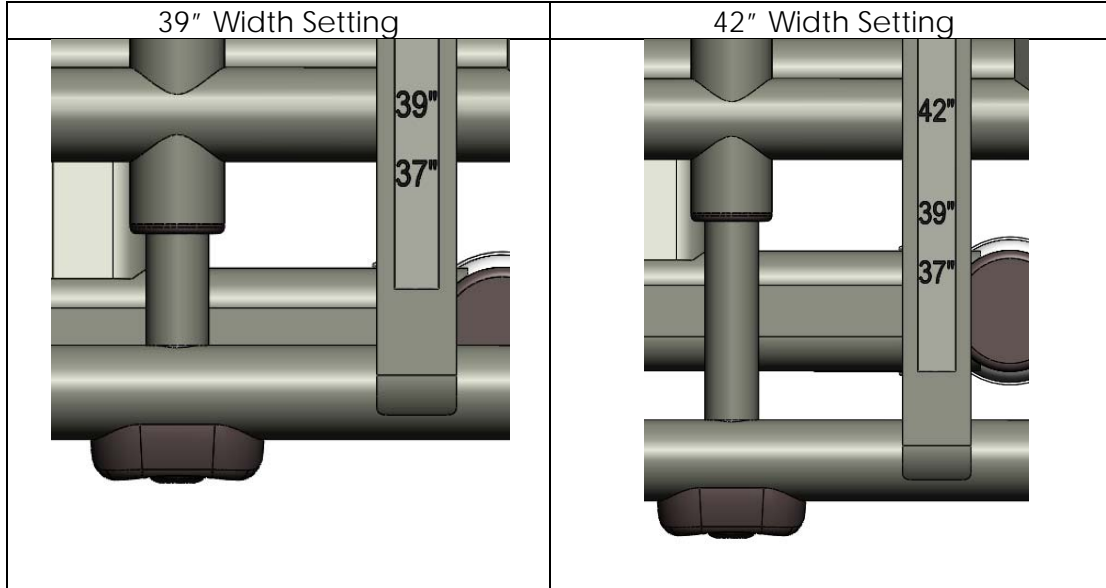

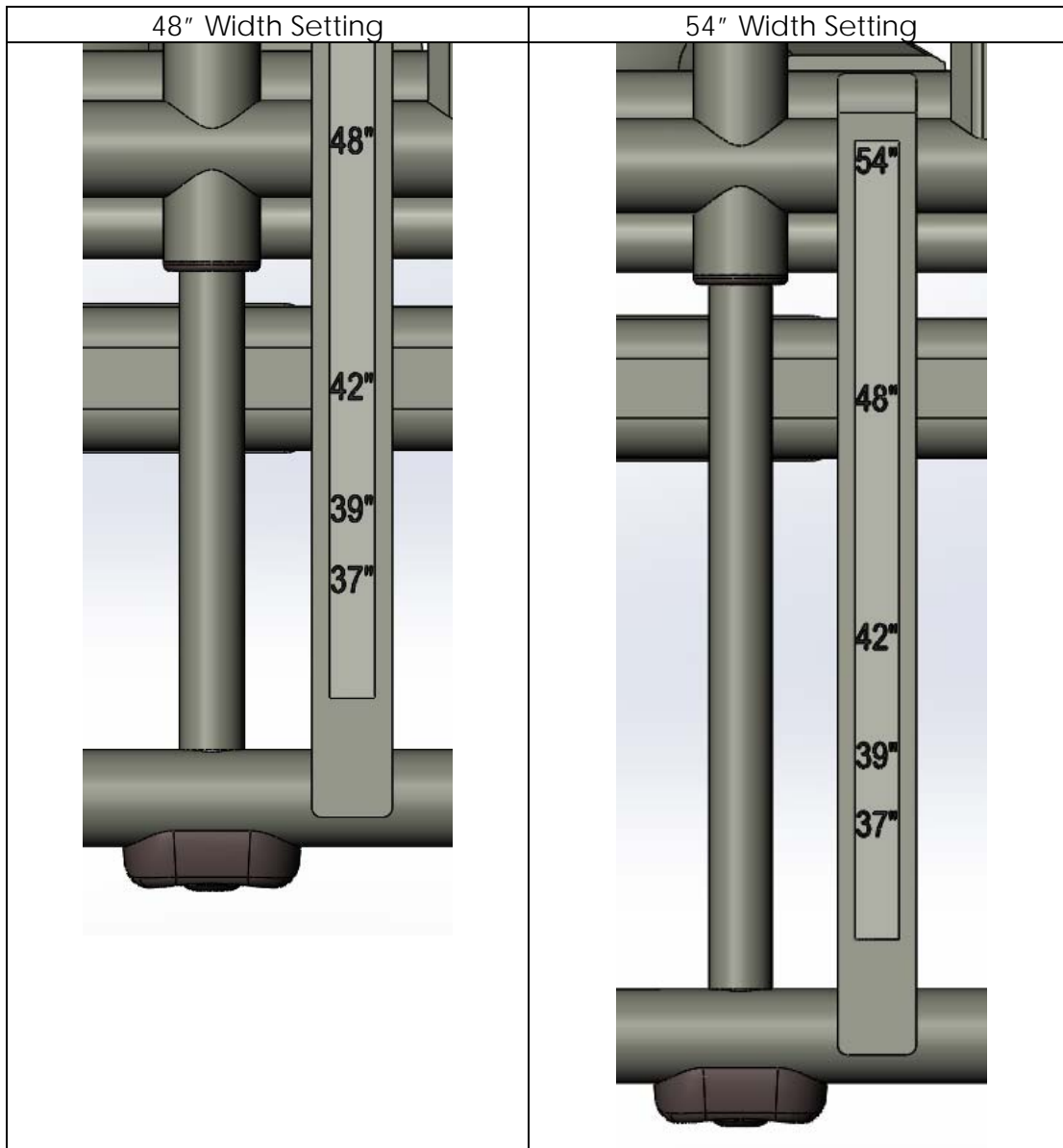

NOTE: This bed can accommodate 39", 42", 48" and 54" mattresses. The appropriate mattress **MUST** be used, such as a Drive Medical Pressure Reduction Mattress for each width setting.

LENGTH EXTENSION (80", 84" and 88")

TOOLS REQUIRED

- | | |
|--|--|
| <ul style="list-style-type: none">• 3/16" Allen wrench | |
|--|--|

- Remove the two 5/16" bolt holding the headboard support bracket in position.



- Adjust the headboard support bracket to the position required for the mattress length being used.
- Re-install the two 5/16" bolt through the frame tube and the headboard support bracket.

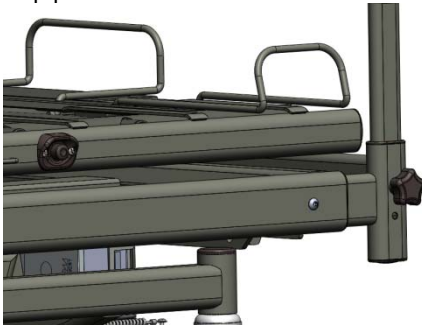

- Repeat process with the footboard support bracket.
- The end mattress retainers must be properly adjusted for the length of the mattress being used.

NOTE: A Gap Fill may also be used to fill in the area at the end of the bed frame so possible Entrapment Issues are minimized.



DANGER

- Possible injury or death may occur if the bed is not adjusted to the proper length for the mattress being used.
- Ensure increase in total length of bed frame does not present a safety hazard or impair access in room. Place new mattress against Mattress Retainer and be sure mattress covers entire length of mattress support surface.

WALL GUARD (No tools required)

NOTE: To install wall guard locate the mount on the cross bar under the head of the bed.

Place the Wall Guard assembly into the receiving tubes located underneath the head section of the bed.



Align holes in Wall Guard with receiving tube and place pins through the holes on each receiving tube to keep Wall Guard in place.

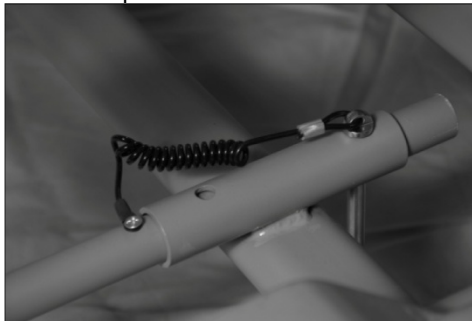
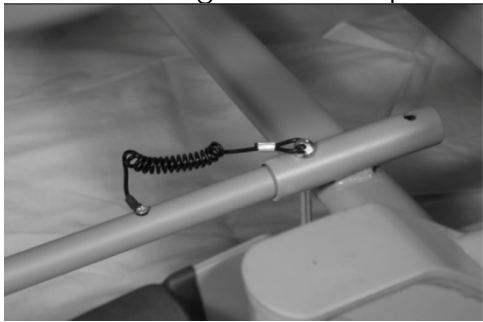

The Wall Guard should now be in place.

BATTERY BACK-UP

TOOLS REQUIRED

• Philips screwdriver	• 3/8" Wrench or socket
-----------------------	-------------------------

NOTE: Battery backup should be used for EMERGENCY purposes ONLY.

- Mount the plastic battery mounting bracket to the steel battery plate at the head end of the bed using the (6) #8 screws and nuts included.

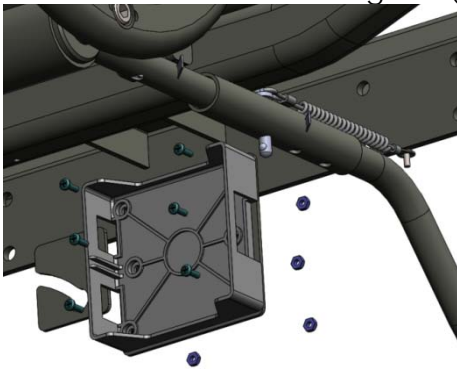

- Slide the battery into place; make sure it is positioned securely into the mounting bracket.

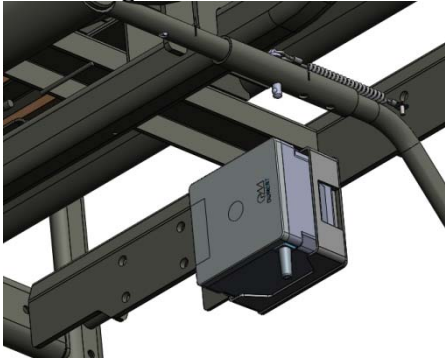

- Attach the cord from the battery into the control box (black color).
- The battery back-up will now work if the bed becomes unplugged from the wall outlet or there is a power failure.

NOTE:

- *Allow the battery to charge for a minimum of 24 hours before first use*
- *Battery back-up is specified as a part of bed*
- *Battery is not to be used in a damp environment such as outdoors*

BATTERY BACK-UP INFORMATION



WARNING

- The battery backup should be used for EMERGENCY PURPOSES ONLY. The only compatible battery backup is a DewertAG7 battery.
- DO NOT use the battery backup to demonstrate or display a bed.
- If the battery backup is used, it MUST be recharged before becoming drained and dormant. If the battery is run dead and left for any extended period of time, the battery can go into HIBERNATION and cannot recover or be recharged.
- Battery function should be checked periodically to insure battery health.
- Primus Medical by Drive cannot be held responsible for improper backup use.
- When a battery is connected to the control box, unplugging the bed from mains power will not switch bed off.
- The battery must be replaced if the housing or cable is damaged.
- The battery must be replaced if there is leakage from the battery.



CAUTION

- If improperly performed, equipment or property DAMAGE or resident INJURY is possible during maintenance.
- The battery is not a toy for children to play with.

Maintenance Notes:

- Following longer periods of storage, the battery may need to be charged and discharged several times so that performance reaches a peak.
- Batteries will lose their charge during storage. Battery should be fully charged prior to storing. A battery in storage should be recharged every 3 months at a minimum.

Care tips

- Make sure the battery is kept clean and dry at all times.
- The battery must receive sufficient ventilation when charging.
- Remove backup battery when bed is not likely to be used for some time.

Safety tips

- Don't open or damage the battery.
- Don't expose the battery to heat or open flames. Avoid storing it in direct sunlight.
- If the battery leaks and you come into contact with the fluid, wash the affected area thoroughly in water and consult a doctor immediately.
- Don't throw the battery into fire, open it, solder or weld to it.

Cleaning Notes

- Before cleaning, always unplug mains cable from wall outlet.
- When cleaning, take care not to damage the connection cable.
- Clean plastic surfaces such as the housing with slightly damp cloth. Never use cleaning agents on battery.
- Never use a high-pressure cleaner on the battery or spray fluids directly onto them using jets. You risk damaging the equipment.
- Solvents, alcohol, bleach, caustic agents, high acid or alkaline solutions or petroleum based products should not be used on the bed.

NOTE: *This bed NOT compatible with wash down tunnels.*



WARNING

Batteries must be disposed of in accordance with local regulations.

BED MOUNTED TRAPEZE

TOOLS REQUIRED:

<ul style="list-style-type: none"> • 7/32" Hex Key 	<ul style="list-style-type: none"> • 9/16" Hex Key
<ul style="list-style-type: none"> • 13/16" Wrench or socket 	<ul style="list-style-type: none"> • 9/16" Wrench or socket

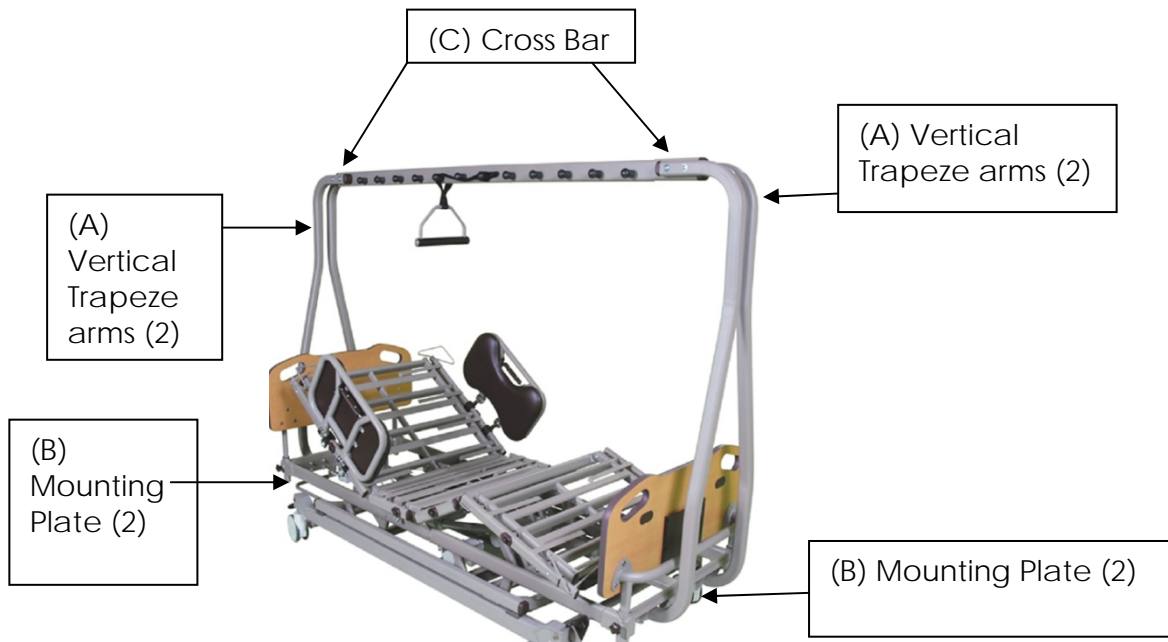

NOTE: *It is recommended that the Trapeze be assembled one end at a time.*

- Mount the (4) vertical Trapeze arms (A) by bolting them to the (2) mounting plates at each end of the bed (B).
- The vertical trapeze arms are mounted to the frame by (4) 3/8" Hex bolts each.
- Use (2) 3/8" bolts to attach the Cross Bar (C) to both vertical Trapeze arms at one end of the bed and then use (2) 3/8" bolts to attach the cross bar to both vertical Trapeze arms at the other end. Finger tighten the locknuts until all (4) arms are secured to the cross bar. Tighten these 4 bolts securely.
- Tighten bolts on both arms on one end of the bed and then the other end.
- Place rubber caps over the 3/8" nuts on the Cross Bar (C).
- Loop Hand Bar straps over desired rungs within easy resident reach.

NOTE: *Make sure all bolts are facing the same way.*

FREQUENTLY USED BED FUNCTIONS

4 Function Hand Pendant

This pendant can be plugged into the left or right side of the bed for the convenience of the resident.

- Hand held pendant can be plugged into the left or right side of the bed frame for the convenience of the resident.
- 1st Set of Buttons: Head deck up and down.
- 2nd Set of Buttons: Foot deck up and down.
- 3rd Set of Buttons: Auto Contour - raise and lower the head and foot decks at the same time.
- 4th Set of Buttons: Bed frame up and down.
- Orange light at bottom of Pendant indicates power is on, Green light on top of Pendant indicates pendant is in use - bed function is in operation.



WARNING

Possible injury or Death may occur due to pendant cord being a source for entangling patient/resident. Patients/residents with decreased mental acuity should NOT have access to pendant.

NOTE: For every 2 minutes of continuous actuator use, the bed actuators must not be used for 18 minutes.

4 Function Staff Control Pad Operation (optional)

This controller is located on the footboard

- 1st Set of Buttons:* Head deck up and down.
 - 2nd Set of Buttons:* Foot deck up and down.
 - 3rd Set of Buttons:** Auto Contour - raise and lower the head and foot decks at the same time.
 - 4th Set of Buttons:* Bed frame up and down.
- * While locked, this feature will not work.
** If head or foot deck movement is locked that deck will not move when auto-contour is used.

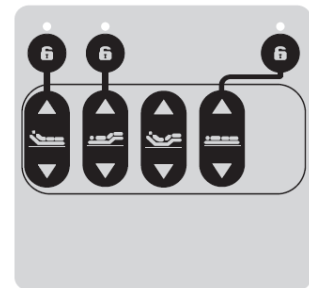

5 Function Staff Control Pad Operation (optional)

This controller is located on the footboard

- 1st Set of Buttons:* Head deck up and down.
- 2nd Set of Buttons:* Foot deck up and down.
- 3rd Set of Buttons:** Auto Contour - raise and lower the head and foot decks at the same time.
- 4th Set of Buttons:* Bed frame up and down.
- 5th Set of Buttons:* Controls Trendelenburg and reverse Trendelenburg positions.

* While locked, this feature will not work.

** If head or foot deck movement is locked that deck will not move when auto-contour is used.

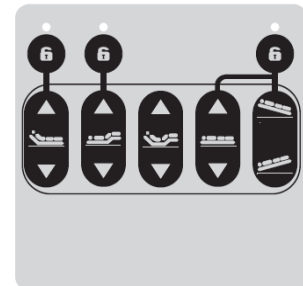

Trendelenburg and Reverse Trendelenburg

- Trendelenburg/Reverse Trendelenburg positioning and Hi/Lo Lockout option with the Attendant Control Panel
 - While in the locked position, these panel features will not work.
 - While in the unlocked position, all features will work.
- The auto-contour button will not work if either the head or foot motions are locked.
- After using Trendelenburg or reverse Trendelenburg, raise the bed to its highest position using the bed frame up button to make the bed deck level.

NOTE: For every two minutes of continuous actuator use, the bed actuators must not be used for 18 minutes.



CAUTION

The use of Trendelenburg and Reverse Trendelenburg functions may not be suitable for certain patients/residents. This function should only be used with the recommendation and supervision of medical personnel.



CRUSH HAZARD

To help eliminate crush hazard, the Trendelenburg and Reverse Trendelenburg functions should be used only when the bed is at or near its highest position.

Cardiac Chair

- This position is achieved by using the Reverse Trendelenburg and Auto Contour buttons.



Power Cord Storage

Power cord strain relief located underneath the bed frame at the head of the bed keeps the power cord off the floor and protects the power cord from getting severed or run over.

NOTE: Disconnect the mains cable (power cord) from the wall outlet and store the power cord when the bed is not in use. Make sure the power cord is secured on the sleep deck and not hanging off the bed where it may be damaged. Secure the power cord to the head end of the bed when moving the bed.

BED MOBILIZATION AND STABILIZATION



WARNING

Unintended bed movement may occur if the caster locks are left unlocked. Unintended bed movement may lead to property DAMAGE or resident INJURY. Never leave a bed unattended while the caster locks are not engaged.

Caster Lock

- To lock the bed use any of the four foot locks located above the casters.

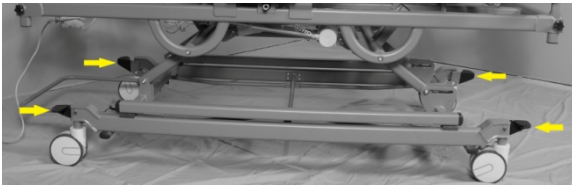

- When using the casters at the head of the bed, the bed will be locked when the left caster lock pedal is up and the right caster lock pedal is down.
- When using the casters at the foot of the bed, the bed will be locked when the left caster lock pedal is up and the right caster lock pedal is down.



CAUTION

Moving the bed while the floor lock or caster lock is engaged may cause DAMAGE to the bed or floor. Do not move the bed unless the floor lock and caster lock are unlocked.

Bed Steering

- Casters at the foot of the bed are your steering casters.
- When caster locks are even on all casters the bed is in Central Steer and can be moved in any direction.



CARE AND MAINTENANCE



CAUTION

- If improperly performed, equipment or property DAMAGE or resident INJURY is possible during maintenance.

NOTICE TO MAINTENANCE STAFF

- Carry out all adjustment and cleaning procedures specified.
- Assembly of this bed and modifications made during the actual service life require evaluation to the requirements of IEC 60601-1 and IEC 60601-2-52.
- Before using, always check function of the bed and all accessories.
- Contact Primus Medical by Drive if you need any help with installation, usage or maintenance of the product.

Corporate Office: Drive Medical, 99 Seaview Blvd.,
Port Washington, NY 11050. Ph: 1-877-224-0946 Fax: 516-988-4601
Website: www.drivemedical.com

Manufacturer: Land America Health & Fitness Co., Ltd

Cleaning Instructions

- If possible, remove resident before cleaning bed.
- Prior to cleaning unplug power supply cords
- Ensure all electrical parts (motors, control boxes, wires and pendant) are not broken. Ensure that NO liquids enter electrical components.
- Remove all gross/solid contaminants, then wash and sanitize all components. DO NOT submerge the bed frame or electrical components.
- Solvents, alcohol, bleach, caustic agents, high acid or alkaline solutions or petroleum based products should not be used on the bed.
- Use standard water pressure. DO NOT power wash or steam clean any parts.
- Rinse completely with water (Maximum temperature 110°F or 43°C). Do not rinse with cold water.
- Ensure all parts are dry before using or storing.

NOTE: *This bed is NOT compatible with wash down tunnels.*

INSPECTIONS



WARNING

Failure to properly maintain your bed may decrease the life expectancy of your product, increase product maintenance requirements and costs and increase risk to residents and staff. ***Always service the bed at the required intervals.***

INITIAL INSPECTION

- Inspection of All Components – Receipt of assembled bed
- Check bed components for obvious damage.
- Inspect power supply cords for cuts and/or damage.
- Check that actuator cords are connected properly to the controller.
- Verify proper functionality of all features.

QUARTERLY INSPECTION

- Check bed for proper function
- Inspect all welds for cracks.
- Inspect bed and Assist Rail bolts, if loose tighten and if missing replace.
- Lubricate clevis pins at hinge points.
- Lubricate tracks of bed for smooth travel.
- Ensure cables routed in the medical bed, will not be squeezed between parts of the medical bed.
- Check all electrical cable strain reliefs to ensure there are no cracks or breaks.

Control Box

- Check power cord for chafing, cuts or wear.
- Ensure all attachment hardware and brackets are tight.
- Check electrical connections for wear or fractures.
- Verify that all actuator connections are tight.
- Ensure all electrical connections are fully engaged.

Pendant

- Check pendant cord for chafing, cuts or wear.
- Check all pendant buttons for proper function.

Actuators

- Check to make sure actuators do not bind at any point throughout their full range of motion.

Authorized Accessories

- Inspect all fasteners for looseness and wear. Replace or tighten as necessary.
- Ensure welds do not have cracks and visually inspect for stress
- Ensure no tubes are bent.

- If the bed has a battery, unplug bed from wall outlet and check for proper function.
- Check staff control panel for proper function.
- Ensure proper function of all accessories.

SEMI-ANNUAL INSPECTION

- Perform all Quarterly inspections plus:
- Check that all casters roll properly.
- Check caster locks for proper function.

Control Box

- Check power cord for chafing, cuts or wear.
- Check electrical connections for wear or fractures.
- Verify that all actuator connections are tight.

Actuators

- Check actuator cords for chafing, cuts or wear.
- Verify that all clevis pins and bowtie clips are in place.
- Check to make sure actuators do not bind at any point throughout their full range of motion.

Authorized Accessories

- Ensure proper function of accessory.
- Ensure no tubes are bent.

ANNUAL INSPECTION

- Perform all Quarterly and Semi-Annual inspections plus:

Mattress Support Surface, Frame and Base Assemblies

- Inspect welds on the mattress support surface, frame and base assemblies for stress fractures.
- Verify all fasteners are tight.
- Inspect fasteners for wear or damage.
- Inspect bed and Assist Rails bolts, if loose tighten and if missing replace.
- Lubricate clevis pins at hinge points.
- Lubricate Hi/Lo tracks of bed for smooth travel.

Actuators

- Inspect push tubes and end connections of all actuators for excess wear or bending.

SERVICING



DANGER SHOCK HAZARD

Possible Shock Hazard may occur if the main power supply cord for the Control Box is not unplugged from the wall outlet before any maintenance is performed on electrical components.

ACTUATORS AND CONTROL BOX

Cord and Socket Identification

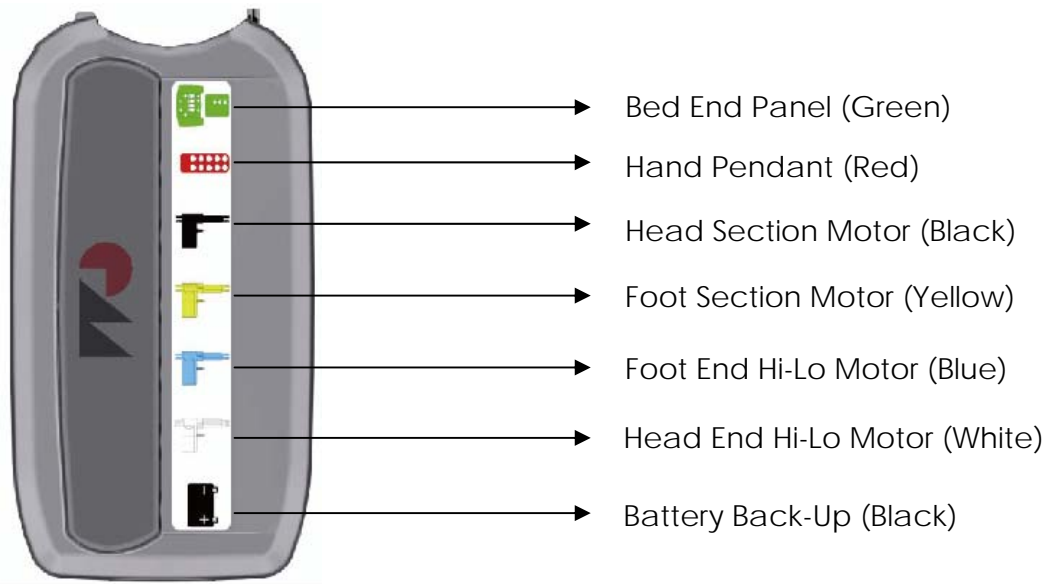

Replacing Control Box

- Unplug mains cable from the wall outlet
- Unplug connections for all actuators and accessories
- Separate the control box from the actuator
- Reinstall the control box on the actuator
- Plug all connections back into control box following color coding
- Plug mains cable into wall outlet
- Test function



WARNING

When routing cables in the medical bed, precautions shall be taken to avoid squeezing between parts of the medical bed.

Replacing Actuators

- Unplug mains cable from the wall outlet
- Identify the actuator to replace
- With the help of a second person place bed on its side to remove the actuators
- Unplug actuator cord from control box
- Actuator is held in place by (2) clevis pins
- Remove bowtie clips from clevis pins
- Slide the clevis pins out of the holes
- Replace the actuator
- To reassemble bed, reverse previous steps, and make sure to:
 - Assemble clevis pins as originally installed with bowtie clips
 - Zip ties should be replaced, with cords in their original position and routing direction to the control box
- Plug mains cable into wall outlet
- Test function



DANGER

Failure to replace bowtie clips on clevis pins at each end of actuator can result in harm to the user, operator and/or equipment.



WARNING

When routing cables in the medical bed, precautions shall be taken to avoid squeezing between parts of the medical bed.

Replacing the AC Power Cord (mains cable)

- Unplug mains cable from wall outlet
- Unplug the mains cable from the control box
- Remove tie-wraps holding power cord in place on frame
- Plug the new power cord into the control box
- Route the new power cord in the same manner as the original cord ensuring use of strain relief device at head end of bed
- Replace tie-wraps to hold power cord to frame
- Plug mains cable into wall outlet
- Test function



WARNING

When routing cables in the medical bed, precautions shall be taken to avoid squeezing those between parts of the medical bed.

TROUBLESHOOTING GUIDE



WARNING

Before doing any repairs or maintenance to the bed frame, read all instructions, cautions, and warnings. Repairs should be done by a skilled technician.

Effect	Possible Cause	Verification	Corrective Action
Bed does not stay in place	Floor lock is not engaged	Caster lock pedal not in locked position	Activate caster Lock
		There may be an object in-between the floor and casters, the floor may be slippery	Clean the floor; remove any objects that may be in the way. Make sure the floor is dry.
	Caster lock is not functioning	Caster lock stuck in one position	Contact Primus Medical by Drive 1-877-224-0946
Actuators not working	Wire connections may be loose or damaged	Visually check wire connections for looseness or fraying	Reconnect any loose wires and/or power cords. If cord is damaged replace immediately
	Hi/Lo lockout may be on	The light on the attendant control panel is on	Unlock panel by pushing lock button and light will go off

Actuators not working	Faulty mains cable (power cord)	Disconnect power cord from bed that is not functioning and use on another bed that is functioning, Reconnect the power and test functions on that bed.	Contact Primus Medical by Drive 1-877-224-0946
	Faulty pendant	Disconnect pendant and test bed function with known working pendant.	Contact Primus Medical by Drive 1-877-224-0946
Bed stalls while operating	Thermal shut down.	Bed works for a short period of time then cuts out. Check for obstructions or any interference with bed frame, such as window seal or too much weight on the bed frame.	Wait a period of time before using the bed frame again. DO NOT keep trying to override, this will shorten the life of your product.
Casters making ratcheting noise	Casters are locked	Casters are locked if the left caster lock pedals are up and the right caster lock pedals are down.	Casters are unlocked- make sure the left caster lock pedals are down and the right caster lock pedals are up.
Bed moving slow	Power cord may be unplugged from wall outlet.	The power cord is not plugged into wall outlet. The bed is running off of the battery back-up.	Plug the power cord back into the wall outlet and bed should move at its normal speed.

WARRANTY

Drive model #P2002 Bariatric Beds are Warranted for a 3 year period from the date of delivery. This guarantee is against defects in materials and craftsmanship, under normal use and service.

This 3-year warranty includes electrical and mechanical parts and components. Bed mounted accessories and Head/Foot boards are covered for 1 year. Welds are covered under a limited lifetime¹ warranty of the product. Steel structural components are covered under the 15-year warranty from the date of delivery. During the warranty period, defective items will be repaired or replaced at Drive's option at no charge.

- ✓ Limited Lifetime warranty on welds.
 - ✓ 15 year warranty on structural steel frame.
 - ✓ 3 year warranty on electrical and mechanical parts and components.
 - ✓ 1 year warranty on all other parts and components.
-
- The P2002 bed should only be used for its intended purpose and must be maintained and serviced in accordance with the instructions contained in this User Manual.
 - This warranty will not apply if damage or mechanical failure is caused by abuse, improper assembly/use/cleaning/repair, accident, negligence, unauthorized alteration, or use in inappropriate environmental conditions, or failure to maintain the product consistent with user and service instructions.
 - Any change, adjustments, or repair not performed by a Drive Medical Authorized Distributor or technician, will void the warranty.
 - This warranty is extended only to the original owner who purchased this product new and unused from Drive Medical or a Drive Medical Authorized dealer/Distributor. Warranty is not extended and is not transferable or assignable to any subsequent purchaser or future owners.
 - Drive Medical's liability shall not exceed the original purchase price of this product.
 - Any Repair work or replacement components provided shall not extend the warranty beyond the original warranty period.
 - Request for Warranty coverage must be accompanied by valid serial number from the bed. Coverage is void if serial number has been removed, defaced, or altered.

¹ Weld lifetime defined as 20 years from date of delivery

Parts

Primus Medical by Drive beds contain a variety of parts that wear from normal use. Some products are not covered under the 3-year warranty but do fall under the 90 day warranty, such as DC batteries. Drive Medical's responsibility under this warranty is limited to supplying replacement parts, servicing or replacing, at its option, which are found to be faulty by Drive Medical.

Warranty replacement parts are covered by the warranty until the product's 3- year warranty period expires. For warranty replacement, Drive Medical requests that broken parts be sent back to them for evaluation. A credit will be issued only after the inspection and determination of cause.

Service

A majority of service requests can be handled by the facility maintenance department with assistance from Drive tech support. If a Drive technician is required, one will be provided by Drive Medical at our discretion.

Most parts can be shipped next day air at the customer's expense.

This warranty is extended to the original purchaser of the equipment.

Bed Frame Serial Numbers

When ordering parts or contacting an Authorized Distributor's Customer Service Department, please include bed's model and serial numbers, found on the identification labels. The identification labels are located under the sleep deck on the frame rail below the mattress support platform on either side of the bed.

Sales and Service

Contact Drive Medical if you need any help with installation, usage or maintenance of the product.

Corporate Office: Drive Medical, 99 Seaview Blvd., Port Washington, NY 11050

Ph: 1-877-224-0946 Fax: 516-988-4601

Website: www.drivemedical.com

Manufacturer: Land America Health & Fitness Co., Ltd.

END OF LIFE DISPOSAL

- Many components of this product may be recycled.
- Please dispose of non-recyclable items properly.

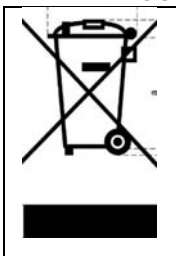
	<p>This marking indicates that this product should not be disposed with other household wastes throughout the EU. To prevent possible harm to the environment or human health from uncontrolled waste disposal, recycle it responsibly to promote the sustainable reuse of material resources. To return your used device, please use the return and collection systems or contact the retailer where the product was purchased. They can take this product for environmental safe recycling.</p>
---	---

NOTE: *The information within this document is subject to change without notice. This manual includes important information about safety of personnel and equipment. As you read through this manual be aware of the four signal indicators.*

APPENDIX

SPECIAL NOTE

For your convenience, we have provided the April 2010 edition of the FDA's guide to bed safety. This information from the FDA's brochure, published by Hospital Bed Safety Workgroup, is replicated verbatim; the latest version is available at <http://www.fda.gov>.

A Guide to Bed Safety Bed Rails in Hospitals, Nursing Homes and Home Health Care: The Facts

Bed Rail Entrapment Statistics

Today there are about 2.5 million hospital and nursing home beds in use in the United States. Between 1985 and January 1, 2009, 803 incidents of patients* caught, trapped, entangled, or strangled in beds with rails were reported to the U.S. Food and Drug Administration. Of these reports, 480 people died, 138 had a nonfatal injury, and 185 were not injured because staff intervened. Most patients were frail, elderly or confused.

** In this brochure, the term patient refers to a resident of a nursing home, any individual receiving services in a home care setting, or patients in hospitals.*

Patient Safety

Patients who have problems with memory, sleeping, incontinence, pain, uncontrolled body movement, or who get out of bed and walk unsafely without assistance, must be carefully assessed for the best ways to keep them from harm, such as falling. Assessment by the patient's health care team will help to determine how best to keep the patient safe. Historically, physical restraints (such as vests, ankle or wrist restraints) were used to try to keep patients safe in health care facilities. In recent years, the health care community has recognized that physically restraining patients can be dangerous. Although not indicated for this use, bed rails are sometimes used as restraints. Regulatory agencies, health care organizations, product manufacturers and advocacy groups encourage hospitals, nursing homes and home care providers to assess patients' needs and to provide safe care without restraints.

The Benefits and Risks of Bed Rails

Potential benefits of bed rails include:

- Aiding in turning and repositioning within the bed.
- Providing a hand-hold for getting into or out of bed.
- Providing a feeling of comfort and security.
- Reducing the risk of patients falling out of bed when being transported.
- Providing easy access to bed controls and personal care items.

Potential risks of bed rails may include:

- Strangling, suffocating, bodily injury or death when patients or part of their body are caught between rails or between the bed rails and mattress.

- More serious injuries from falls when patients climb over rails.
- Skin bruising, cuts, and scrapes.
- Inducing agitated behavior when bed rails are used as a restraint.
- Feeling isolated or unnecessarily restricted.
- Preventing patients, who are able to get out of bed, from performing routine activities such as going to the bathroom or retrieving something from a closet.

Meeting Patients' Needs for Safety

Most patients can be in bed safely without bed rails. Consider the following:

- Use beds that can be raised and lowered close to the floor to accommodate both patient and health care worker needs.
- Keep the bed in the lowest position with wheels locked.
- When the patient is at risk of falling out of bed, place mats next to the bed, as long as this does not create a greater risk of accident.
- Use transfer or mobility aids.
- Monitor patients frequently.
- Anticipate the reasons patients get out of bed such as hunger, thirst, going to the bathroom, restlessness and pain; meet these needs by offering food and fluids, scheduling ample toileting, and providing calming interventions and pain relief.

When bed rails are used, perform an on-going assessment of the patient's physical and mental status; closely monitor high-risk patients. Consider the following:

- Lower one or more sections of the bed rail, such as the foot rail.
- Use a proper size mattress or mattress with raised foam edges to prevent patients from being trapped between the mattress and rail.
- Reduce the gaps between the mattress and side rails.

Which Ways of Reducing Risks are Best?

A process that requires ongoing patient evaluation and monitoring will result in optimizing bed safety. Many patients go through a period of adjustment to become comfortable with new options. Patients and their families should talk to their health care planning team to find out which options are best for them.

Patient or Family Concerns About Bed Rail Use

If patients or family ask about using bed rails, health care providers should:

- Encourage patients or family to talk to their health care planning team to determine whether or not bed rails are indicated.
- Reassure patients and their families that in many cases the patient can sleep safely without bed rails.
- Reassess the need for using bed rails on a frequent, regular basis.

To report an adverse event or medical device problem, please call FDA's Med Watch Reporting Program at 1-800-FDA-1088.

For additional copies of this brochure, see the FDA's [Hospital Bed website](#).

For more information about this brochure, contact Beryl Goldman at 610-335-1280 or by e-mail at bgoldman@kendaloutreach.org. She has volunteered to answer questions.

For information regarding a specific hospital bed, contact the bed manufacturer directly.

Developed by the Hospital Bed Safety Workgroup

Participating Organizations:

- AARP
- ABA Tort and Insurance Practice Section
- American Association of Homes and Services for the Aging
- American Health Care Association
- American Medical Directors Association
- American Nurses Association
- American Society for Healthcare Engineering of the American Hospital Association
- American Society for Healthcare Risk Management
- Basic American Metal Products
- Beverly Enterprises, Inc.
- Care Providers of Minnesota
- Carroll Healthcare
- DePaul College of Law
- ECRI
- Evangelical Lutheran Good Samaritan Society
- Hill-Rom Co., Inc.
- Joerns Healthcare, Inc.
- Joint Commission on Accreditation of Healthcare Organizations
- Medical Devices Bureau, Health Canada
- National Association for Home Care
- National Citizens' Coalition for Nursing Home Reform
- National Patient Safety Foundation
- RN+ Systems
- Stryker Medical
- The Jewish Home and Hospital
- Untie the Elderly, The Kendal Corporation
- U.S. Food and Drug Administration

Revised April 2015



Drive Medical, 99 Seaview Blvd., Port Washington, NY 11050

Ph: 1-877-224-0946 Fax: 516-988-4601

www.drivemedical.com