



# FloorBed 6 Instruction Manual

IFU-FL6-001US Rev 01

**Accora**

## Contents

Title	Page
Product Overview -----	3
 General Warnings-----	4
1. Means of Delivery -----	5
2. Safety Instructions-----	5
3. Use Environments -----	6
4. Intended Use-----	6
5. Technical Specification -----	7
6. Accessories -----	8
7. Electrical Specification-----	8
8. Assembly -----	9
9. Assembly of Side Panels (optional) -----	12
10. Bed Controls and Indicators-----	14
11. Floor-level Function -----	16
12. Length Adjustment -----	17
13. Functionality Check -----	18
14. Using the Castor Brakes -----	19
15. Mattress Selection-----	19
16. Moving and Repositioning -----	20
17. Cleaning & Disinfection-----	20
18. Troubleshooting -----	21
19. Storage-----	22
20. Daily Inspection -----	22
21. General Maintenance -----	23
22. Guarantee -----	23
23. Disposal-----	23
24. EMC Statement -----	24
25. Table of Symbols -----	28
26. Contact Details -----	30

## Welcome

Dear Customer,

Thank you for purchasing an Accora healthcare product. Before operating the bed, you must read and understand all the instructions in this manual. All actions and handling of the bed must be performed in accordance with the instructions in this manual.

Please ensure that the manual is available to users and operators throughout the bed's service life.

If you need further information, please contact us. See section 26 for region specific contact details.

### General

In the US, the FloorBed 6 is classified as a Class 2 Medical Device.

The FloorBed 6 is classified as a Class 1 Medical Device in accordance with the Medical Device Regulation 2017/745.



### Notice to User

If a serious incident occurs in relation to this medical device, affecting the user or the patient, then the user or patient should report the serious incident to the medical device manufacturer (or distributor) and, in the European Union, the user should also report the serious incident to the Competent Authority in the member state where they are located.



Accora Ltd, 38 Main Street,  
Swords, Co. Dublin, Ireland, K67 E0A2  
T: +353 (0)1 695 0614

### Design Policy and Copyright

® and ™ are trademarks belonging to Accora Ltd unless otherwise stated. As our policy is one of continuous improvement, we reserve the right to modify designs without prior notice. © Accora Ltd 2020.

## Product Overview

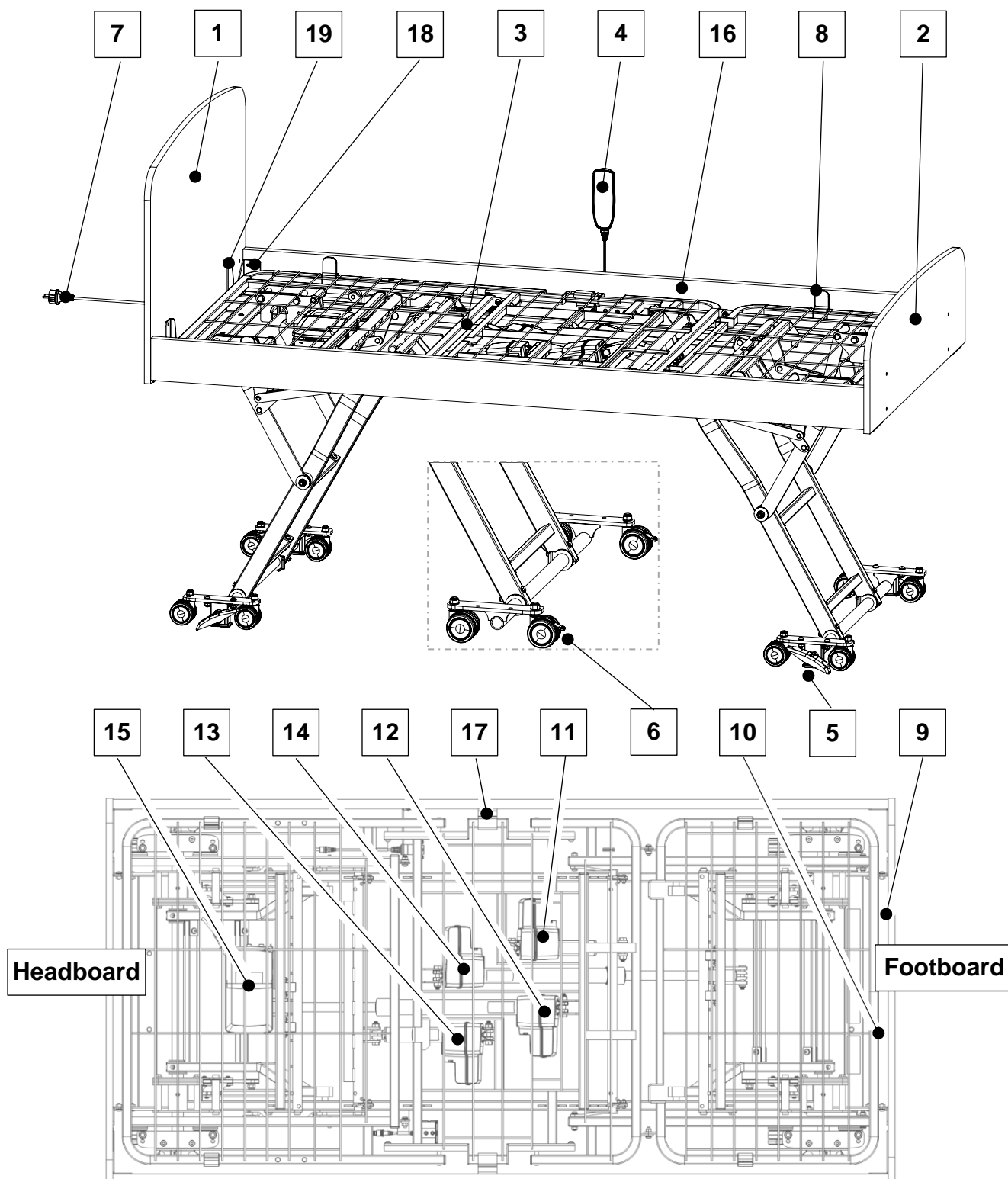

- |  |  |                               |
|--|--|-------------------------------|
| 1. Headboard (design may vary)         | 8. Mattress guides                             | 15. Control Box               |
| 2. Footboard (design may vary)         | 9. UDI Label                                   | 16. Side panel (optional)     |
| 3. Mattress platform                   | 10. Manufacturers nameplate inc. serial number | 17. Side panel centre bracket |
| 4. Handset                             | 11. Legrest actuator                           | 18. Side panel end bracket    |
| 5. Central brake lever                 | 12. Main lift actuator – Head end              | 19. Headboard bracket         |
| 6. Braked castors (NSB-0-FL6-000 only) | 13. Backrest actuator                          |                               |
| 7. Power cable                         | 14. Main lift actuator – Foot end              |                               |



## General Warnings -----

1. Keep this Instruction Manual available for future reference.
2. These instructions must be observed to ensure the safe and effective use of this bed and the safety of users and caregivers.
3. This bed must be assembled, positioned and used in accordance with these instructions.
4. The safety features for operating the bed and instructions concerning the bed must be strictly observed.
5. This bed must not be exposed to smoke, naked flame, extreme temperature, flammable gases or other hazardous substances or situations.
6. Do not smoke in or around the bed.
7. Accora shall not be held liable for any damage, injuries or accidents arising from unauthorised modifications, non-genuine spare parts, negligence or use that is at variance with this manual which can result in serious injury or death.
8. Electrical equipment can be hazardous if misused or abused. Ensure the electrical supply cable is not damaged by crushing and does not create a trip hazard.
9. Inappropriate routing of accessory cables, e.g. mattress air pump cable, could lead to dangerous electric hazards if squeezed or crushed between moving parts. The bed must not be used if there is any visible damage to any cables.
10. When routing cables for other electronic equipment used with the bed (e.g. air mattress pump), ensure cables cannot be squeezed, crushed or damaged by the moving parts on the bed.
11. Inappropriate use of the power supply cable (e.g. kinking, shearing) could lead to dangerous electric hazards. The bed must not be used if there is any visible damage to this cable.
12. The hand control should be positioned to avoid strangulation risk. Inappropriate use of the hand control (e.g. kinking, shearing) could lead to dangerous electric hazards. The bed must not be used if there is any visible damage to the handset or cable.
13. Electrical installations must meet local requirements.
14. Only use accessories that are compatible with this bed as supplied by Accora. Incompatible accessories can create hazards and entrapment risks.
15. Keep children and pets away from this bed unless supervised by an adult as there is a risk of injury and/or choking on small parts.
16. Never stand on the bed.
17. Do not lower the bed while a hoist that extends beneath the bed is being used. Hoist access is obtained when the bed is raised to 45cm measured from the floor to the mattress platform base.
18. The bed should be left in the floor-level position when the patient is unattended in order to reduce risk of injury due to falls.
19. If using the electronic functions adversely affects the health of the patient, disconnect the power supply and only use the bed in the static mode.
20. Do not move the bed when it is in the floor-level position.
21. This bed should not be used for transporting patients in vehicles.
22. This bed is not recommended for users outside of the weight and height specifications detailed in Section 5
23. Before operating this bed, ensure the patient is safely positioned to reduce the risks of bed fall and entrapment.
24. Always check for any entrapment risks under the bed before lowering to the floor-level position.

25. Patients, or users, should be risk assessed to ensure they are able to understand this manual and to operate FloorBed safely without risk to themselves or others.
26. If the combined weight of the mattress and accessories exceeds 35kg, the maximum patient weight must be reduced accordingly.
27. Take care when moving the bed over door thresholds.
28. In high ambient temperatures electrical enclosures (e.g. handset) may get warm during prolonged use.
29. When moving the bed, the power cable must be disconnected from the wall socket and secured on the bed to avoid damage to the cable.

## 1. Means of Delivery-----

The bed is supplied boxed with the electrical system fully assembled. The headboard and footboard and any accessories are supplied separately.

An inspection must take place upon receipt to ensure the delivery is complete and undamaged.

Any missing parts, faults or damage must be reported immediately to the carrier and Accora in writing.

If the bed needs transporting between facilities, consider if the headboard and footboard should be removed. Ensure manual handling guidelines are followed.

## 2. Safety Instructions -----

1. Before using the bed, you must read the instruction manual and use the bed in accordance with it.
2. The bed must not be used if faults have been detected on it that may injure the patient, staff or a third person, the bed or the surroundings.
3. The bed must only be operated by persons who are able to operate it in accordance with the manual.
4. The operating staff must make the patient aware of the control functions that apply to the patient subject to an assessment by a professional.
5. Before using the bed, the operator should understand the bed and its functionality.
6. The safe working load, as specified in Section 5, must never be exceeded.
7. If there is a patient on the bed, the bed castors must be locked as an unlocked bed castor can result in movement of the bed and injury to a patient who leaves the bed or changes position.
8. The height of the mattress platform must be adjusted to the correct height for the condition of the patient.
9. Only one person should occupy the bed at any time.
10. When operating the moving parts of the bed, care must be taken to ensure that the patient, other people and objects do not become trapped.
11. If a lifting pole or infusion stand is fixed to the bed, increased attention must be taken during movement, lifting or tipping, to the space around the lifting pole and infusion stand, so that the equipment is not damaged.
12. Before cleaning the bed, the electrical supply must be disconnected.

### 3. Use Environments-----

This bed is intended for use in the following application environments:

1. Application Environment 3 - Long-term care in a medical area where medical supervision is required and monitoring is provided if necessary and ME equipment used in medical procedures may be provided to help maintain or improve the condition of the patient. Note, this includes use in nursing homes and in rehabilitation and geriatric facilities.
2. Application Environment 4 - Care provided in a domestic area where ME equipment is used to alleviate or compensate for an injury, disability or disease.
3. Application Environment 5 – Outpatient (ambulatory) care, which is provided in a hospital or other medical facility, under medical supervision where ME equipment, is provided for the need of persons with illness, injury or disability for treatment, diagnosis or monitoring.

Electrical installations must meet local requirements.

### 4. Intended Use -----

FloorBed 6 is intended to be used as a nursing bed in the Use Environments listed. The bed is intended for adult patients above 57.5in/146cm in height who do not exceed the maximum patient weight of 525lb/240kg.

Subject to a risk assessment, the bed may help to maintain, improve, compensate or alleviate the condition of the patient.

The patient user group is adult patients above 57.5in/146cm height.

A risk assessment must be carried out before the bed is used by a patient.

## 5. Technical Specification-----

The table below lists the FloorBed 6 part number and description.

Part number	Description
NSB-2-FL6-000US	<ul style="list-style-type: none"> <li>• Four section profiling</li> <li>• Height range 3.9-31.5in, 10-80cm</li> <li>• Mattress deck/platform 80x36in, 200x90cm</li> <li>• SWL 600lb, 275kg</li> <li>• Max user weight 525lb, 240kg (38st)</li> <li>• Centrally braked castors at both ends</li> <li>• Head and footboards supplied separately</li> </ul>

Description	Value
Overall dimensions	1015mm W x 2090mm L 40in W x 82.3in L
Mattress size	See mattress selection – section 15
Bed castor	83mm diameter
NSB-0-FL6-000	8 x 63mm castors, 4 braked and 4 unbraked
NSB-2-FL6-000	8 x 63mm castors, central brake at both ends
Mattress platform height	100mm to 800mm 3.9in to 31.5in
Maximum trapeze self-assist pole lifting load	165lbs / 75kg
Safe Working Load**	600lbs / 275kg / 43st
Maximum Patient Weight**	525lbs / 240kg / 38st
Audible noise	<60 dBA
Mass of Bed	265lbs / 120kg
Liquid ingress protection	IPX6
Trendelenburg function	12 degrees
Expected service life	Typically 5 years

### Environmental information:

Condition	Temperature Range	Relative Humidity	Atmospheric pressure	Meters above sea level
Operating	+5°C to +40°C +41°F to +104°F	20% to 80% (Non-condensing)	700 hPa to 1060 hPa	Max. 3000 meters
Transport/storage	-10°C to +50°C 14°F to +122°F			

If the bed is stored in conditions outside the normal operating range, it should be allowed time to stabilise, in normal operating conditions, before use.

FloorBed 6 mattress platform range including maximum angles:

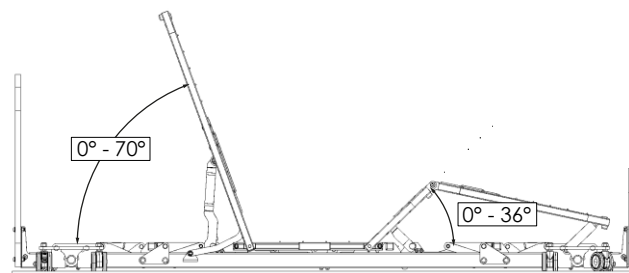

Figure 5.1

\*\* The safe working load is calculated as follows (as specified by EN 60601-2-52:2015):

Maximum patient weight:	240kg	38st	522lb
Mattress	20kg	3st	44.5lb
Accessories	15kg	2st	33.5lb
TOTAL (Safe working load)	275kg	43st	600lb

## 6. Accessories -----





Due to differing regulatory requirements, not all the accessories are available in all regions.

Description	Part number
Width adjustment kit (extends width of bed by 15cm)	WDEX-0-FL6-000
Standard bed lever assist bar	STLEV-0-FL6-000
Long bed lever assist bar	STLEVLKT-0-FL6-000
Lifting pole	LIFOL-0-FL6-000
Wall protection bar	WALLB-0-FL6-500
High safety mat	SAFTH-0-FL6-500

## 7. Electrical Specification -----

Duty Cycle: Intermittent operation 2 min/18 min. After the maximum continuous action of two minutes, there must be a break of 18 minutes.

Description	Value
Supply voltage	100 – 240V
Supply frequency	50/60Hz
Maximum supply current	3.9 Amps
Degree of protection against liquid ingress	IPX6
Degree of protection against electrical shock	Class II Double Insulated

Symbol	Definition
	The B symbol indicates this product has a degree of protection against electric shock for type B equipment.
<b>IPX6</b>	Degree of protection against liquid ingress.
	Do not dispose of in household waste.
	Degree of protection against electric shock: Class II Double Insulated.
	For indoor use only

For or a full list and explanation of symbols used see Section 25.

## 8. Assembly -----



### WARNING

Assembly **MUST** be carried out by suitably trained and qualified personnel.

All functions **MUST** be tested and approved after assembly by suitably trained and qualified personnel.

Assembly **MUST** take place in a clear, uncluttered area and children and pets should be kept away.

If bed has become soiled or contaminated during transit refer to cleaning and disinfection instructions.

Ensure headboard and footboard are assembled as shown below so that the Trendelenburg function works correctly.

The left and right of the bed are as seen by a person lying in the bed. See figure below.

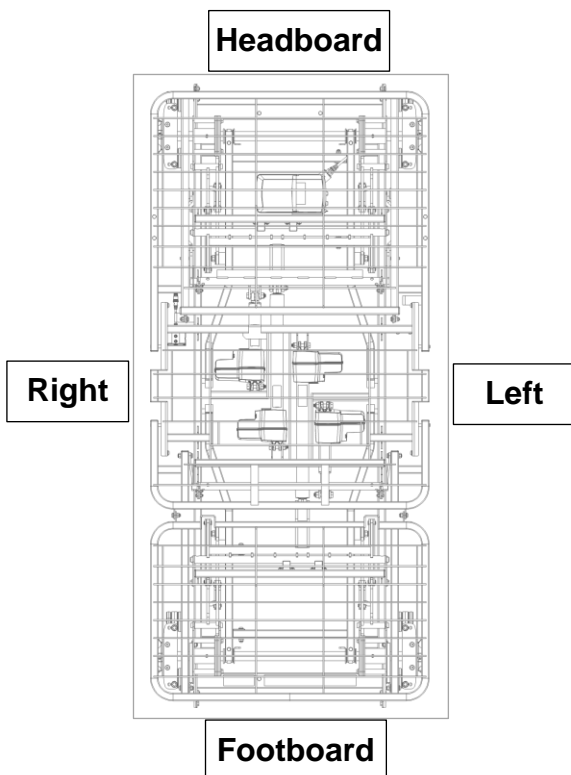

1. Check that the delivery is complete and whether any visible damage has occurred to the bed during transport.

2. Remove the packaging and identify all the components:

### Bed frame

1. Mattress platform.
2. Handset.
3. Mattress guides (4 off).
4. Headboard & footboard brackets and fixings.
5. Headboard & Footboard (supplied separately).
6. Side panels and fixing bracket (optional, supplied separately).

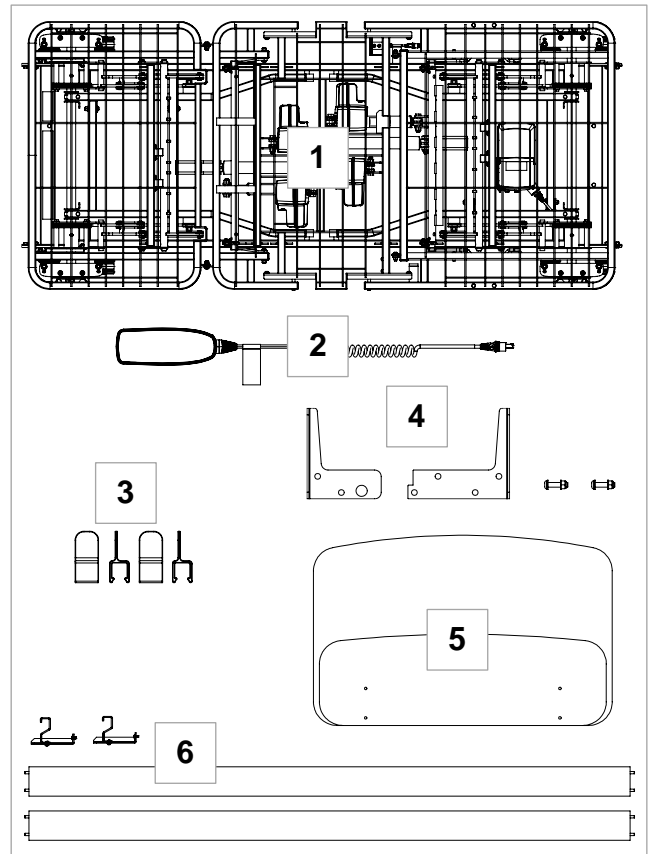

Figure 8.1

3. The headboard and footboard brackets have different fixing holes as shown in Figure 8.2.

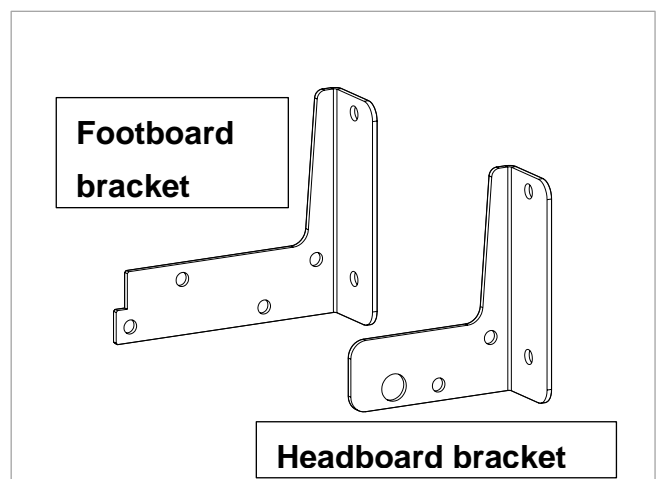

Figure 8.2

4. There are two handset ports located on either side of the bed as shown by 1 (right side) and 2 (left side) on Figure 8.3. The bed will be delivered with the handset cable plugged into the socket in position 2 on the left side.

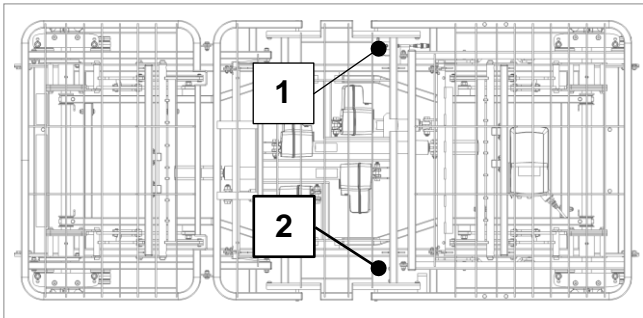

Figure 8.3

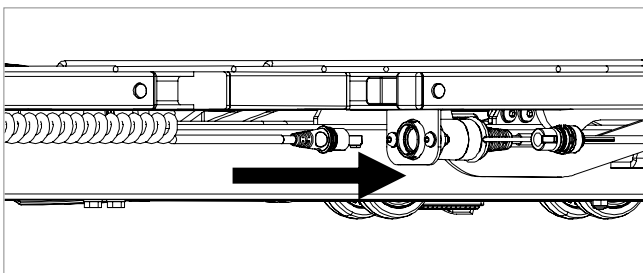

Figure 8.4

5. To move the handset cable to the right side of the bed, remove the handset cable connector from the left side socket. Insert the captive blanking plug into the socket.
6. Remove the plug from the right side socket and insert the handset cable connector.
7. Ensure the bed is positioned so that the mains plug can be easily put into a mains socket. Plug the power supply cable into a mains supply socket.
8. Using the handset, raise the bed to the highest position, see Section 10.
9. The headboard and footboard fixing kit comprises the following items:
  1. 2 x headboard fixing brackets
  2. 2 x footboard fixing brackets
  3. 8 x M8 x 20mm bolts
  4. 8 x M8 x 35mm bolts
  5. 24 x M8 washers
  6. 8 x M8 locking nuts
  7. 1 x 5mm Allen key

10. Select the correct brackets for headboard and footboard. The headboard bracket only has one fitting position; the footboard bracket has two fitting positions so the bed can be adjusted in length.

11. Position the brackets on the footboard as Figure 8.5 – note the orientation of the brackets.

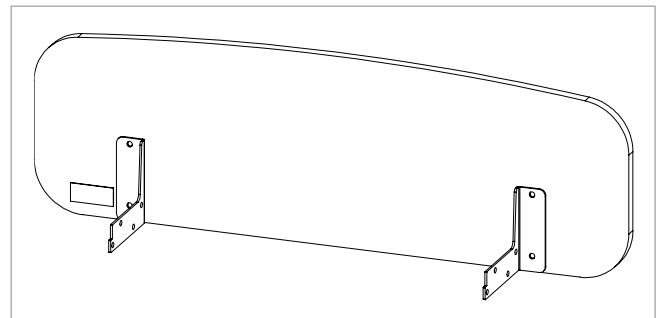

Figure 8.5

12. Fix the brackets to the footboard using the M8 x 35mm bolts, nuts, and washers provided as shown in Figure 8.6. Tighten using the 5mm Allen key and a 13mm spanner.

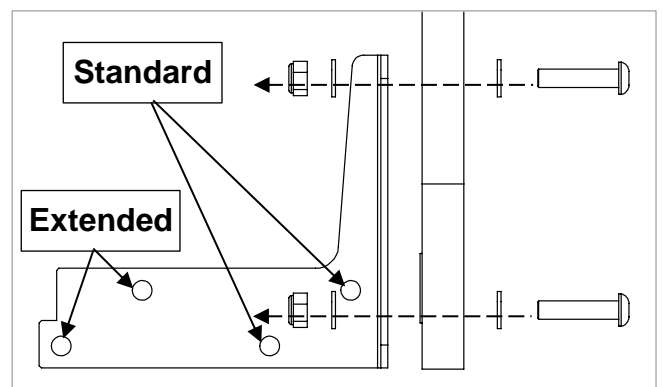

Figure 8.6

13. Locate the mounting brackets into the channel sections on either side of the foot end of the bed; slide the footboard and brackets all the way into the channels as Figure 8.7.
14. For the bed at the standard length for a 80in mattress, use the bolt holes marked 'Standard' in Figure 8.6. For the bed at the extended length for a 84in mattress, use the bolt holes marked 'Extended' in Figure 8.6.

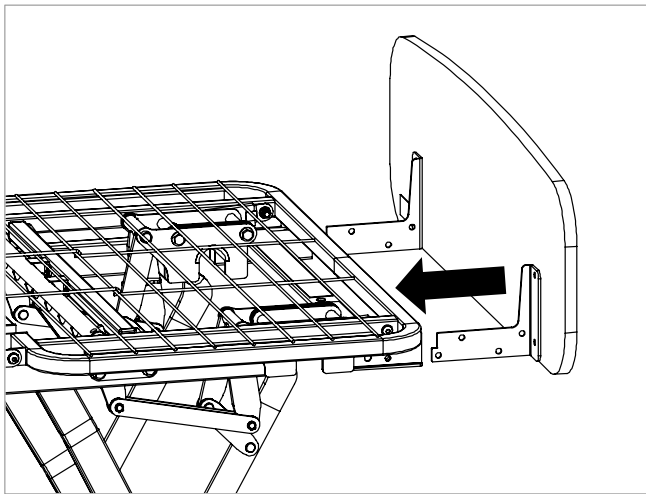

Figure 8.7

15. Align the bolt holes and secure the mounting brackets using the M8 x 20mm bolts and washers provided as shown in Figure 8.8. Tighten using the 5mm Allen key.

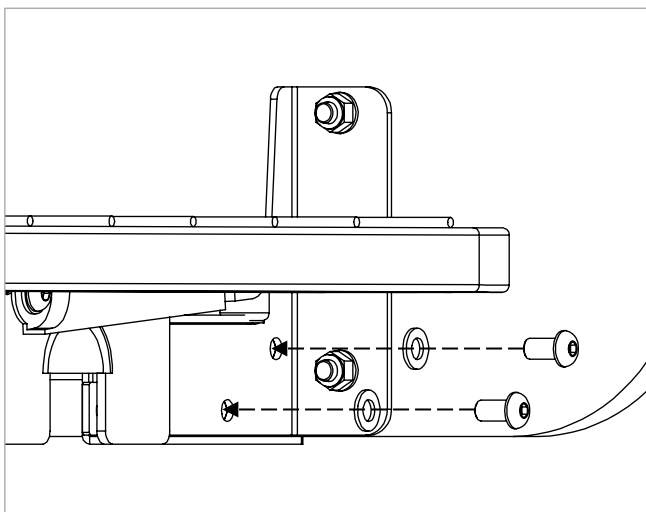

Figure 8.8

16. Fit the headboard mounting brackets to the channel sections on either side of the head end of the bed using M8 x 20mm bolts and washers. Ensure the locating hole on the brackets fits over the locating lug in the channel (see Figure 8.9).

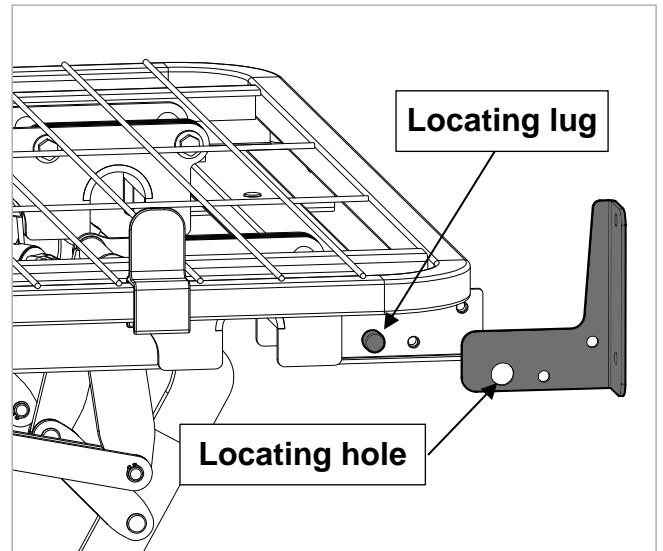

Figure 8.9

17. Fit the headboard to the headboard brackets using the M8 x 35mm bolts, nuts, and washers. Tighten all fixings using the 5mm Allen key and a 13mm spanner.
18. Install the four mattress guides as shown in Figure 8.11 (note the orientation) in the locations shown in Figure 8.10. They may be fitted in any position within the locations shown.

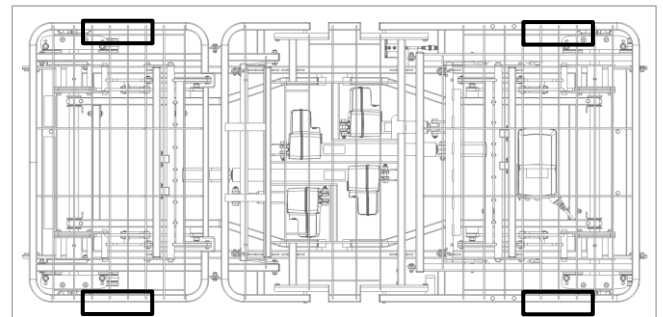

Figure 8.10

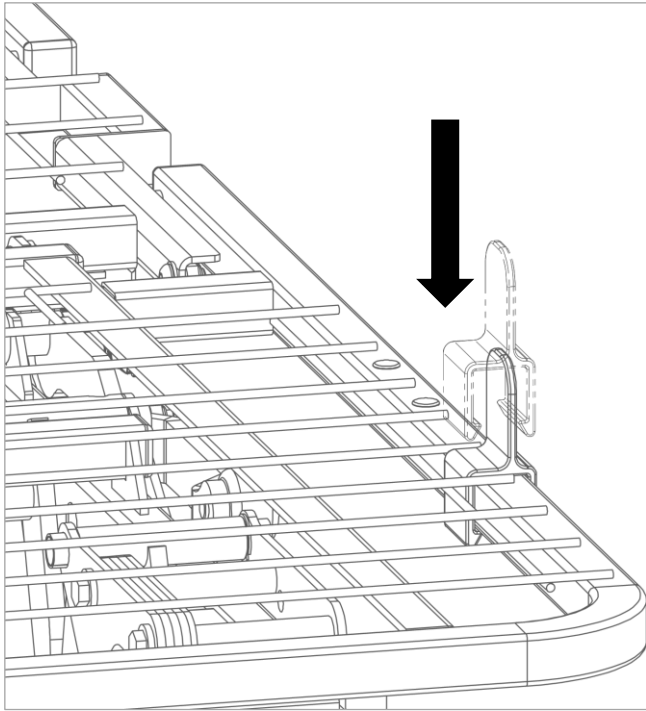

Figure 8.11

19. Carry out the functionality check in Section 13.
20. The FloorBed 6 is now ready for use.

## 9. Assembly of Side Panels (optional)

1. The two side panels will be supplied with a fixing kit which contains:
  1. 4 x side panel end brackets
  2. 2 x side panel middle brackets (each comprising a plate and claw)
  3. 24 x M6 x 20 bolts
  4. 24 x M6 washers
  5. 1 x 4mm Allen key
2. The side panel end bracket is shown below in Figure 9.1.

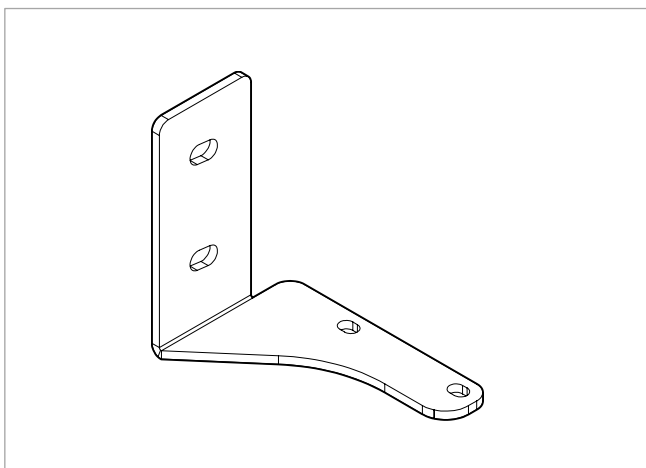

Figure 9.1

3. The side panel middle bracket is shown below in Figure 9.2. The claw may be fitted to the plate in one of four positions, depending on the configuration of the bed:

1. Bed 42in wide (with width adjustment kit fitted)
2. Bed 36in wide (standard width)

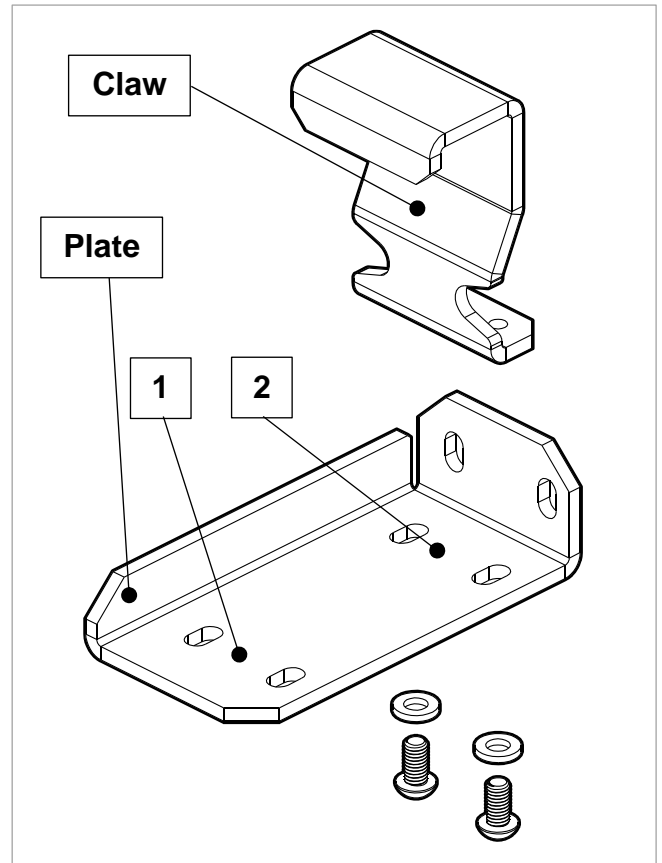

Figure 9.2

4. Fit the claw to the plate in the correct position for the bed configuration using two M6 x 20 bolts and M6 washers. Leave the bolts slightly loose.
5. Fit the four side panel end brackets to the bottom edge of the head and footboards with the M6 x 20mm bolts and washers as shown in Figure 9.3. Leave the bolts slightly loose.

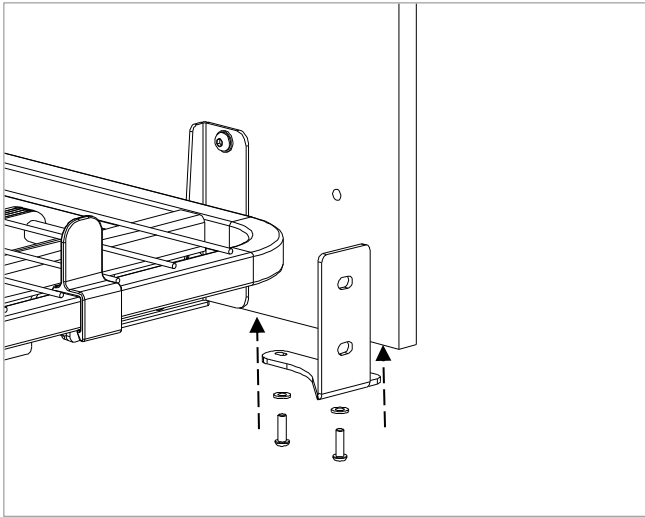

Figure 9.3

6. Fit the assembled middle bracket to the side panel. There are two sets of fixing holes on each side panel, depending which side of the bed the side panel is fitted, as shown in Figure 9.4. Fit the bracket to the set of holes closest to the headboard using the M6 x 20 bolts and M6 washers as shown in Figure 9.5. Tighten the bolts using the 4mm Allen key.

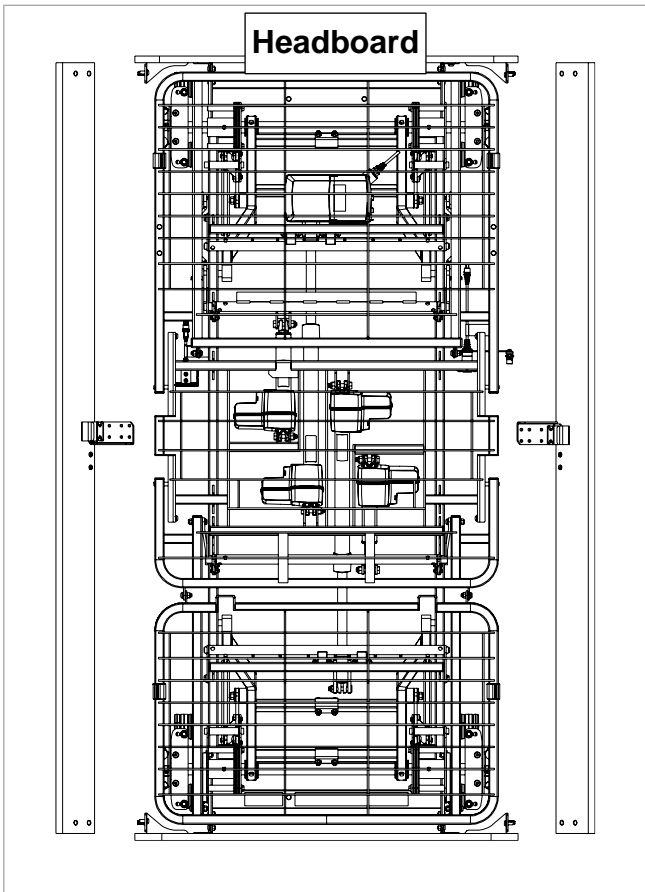

Figure 9.4

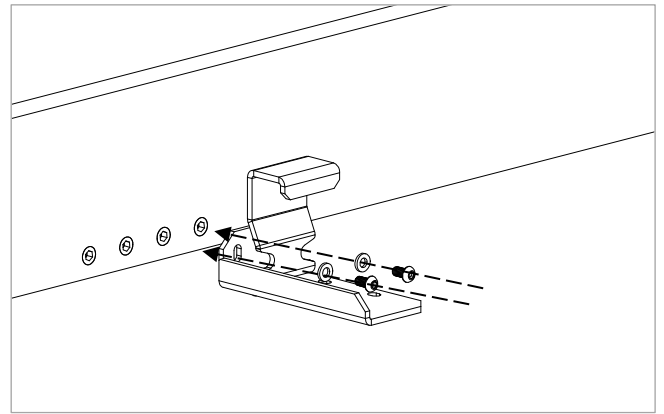

Figure 9.5

7. Mount the side panels onto the bed frame as shown in Figure 9.6. Position the side panel between the headboard and footboard and fit the centre bracket claw over the bed frame side bar.

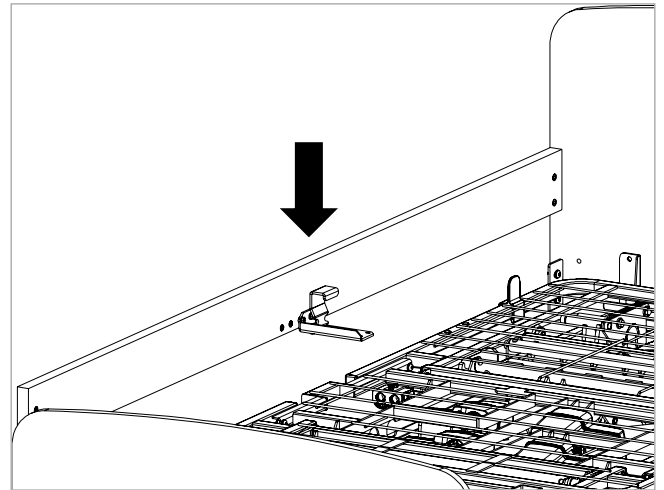

Figure 9.6

- Fit each side panel to the side panel end brackets with the M6 x 20mm bolts and M6 washers as shown in Figure 9.7. Leave the bolts slightly loose.

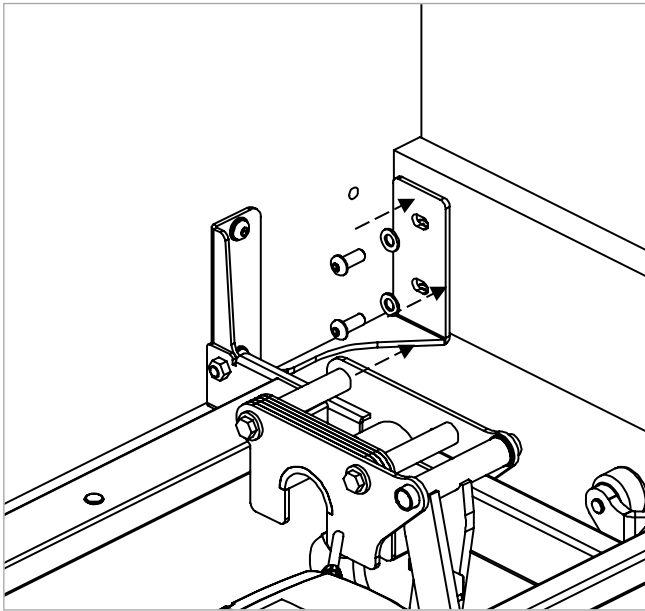

Figure 9.7

- Adjust the side panels so they are fitted snugly against the headboard and footboard. Tighten the bolts previously left loose using the appropriate Allen key.
- Carry out the functionality check in Section 13.

## 10. Bed Controls and Indicators-----



### WARNING

Bed positioning **MUST** be carried out by suitably trained and qualified personnel.

Patients should only be allowed to operate the bed independently if they are able to understand the safety instructions in this manual and have been risk assessed as appropriate to do so.

Make sure the castor brakes are in the locked position before using the handset to change the positions of the bed.

Always engage the brakes when the bed is stationary or left unattended.

Check for obstructions around, above and below the bed frame and position the bed so that it can operate through the full height range without any possibility of obstruction or entrapment.

Use of the legrest function must be risk assessed as it may cause unintentional displacement when used with patients of smaller stature.

Sharing the bed with a patient (particularly a child) carries the risk of lying on the patient and causing suffocation or the patient being wedged against the side of the bed.

Use of wedges, supporting and positioning devices may cause entrapment and a risk of suffocation.

Smaller patients may need additional support to achieve a semi-Fowler's position.

Always store the handset in a safe place when not in use to avoid risk of strangulation and entrapment in the bed mechanism, for example on the outside of the headboard or footboard.

Handset and cable must be kept out of reach of children.

The handset is used by the user or caregiver to change the position of the of the backrest and legrest sections and to adjust the height of the mattress platform of the bed. Always check for obstructions before the bed is raised or lowered. Before using the control, the operating staff should explain to the patient how the bed can be positioned. If the medical staff state that the patient’s medical condition is inappropriate for the patient to be able to adjust the bed independently, the bed’s position must only be adjusted by the caregiver.

The handset has the following controls and indicators:

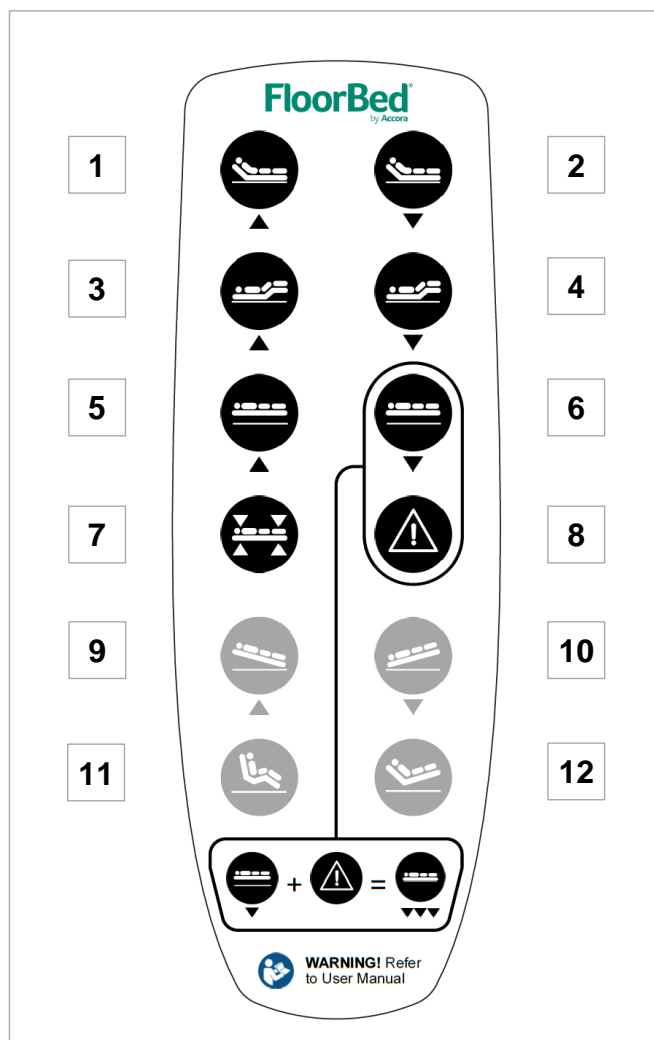

Figure 10.1

- |           |           |  |
|-----------|-----------|--|
| <b>1</b>  | <b>2</b>  | Backrest – Raise / Lower   |
| <b>3</b>  | <b>4</b>  | Legrest – Raise / Lower  |
| <b>5</b>  | <b>6</b>  | Mattress Platform – Raise / Lower  |
| <b>7</b>  |           | Reset to flat and level position   |
|           | <b>8</b>  | Function safety button (must be pressed together with button number 6 or 10) |
| <b>9</b>  | <b>10</b> | Reverse Trendelenburg and Trendelenburg function                             |
| <b>11</b> | <b>12</b> | Chair position and Semi-Fowler's position                                    |

**Note:** If the patient is unable to operate the bed safely, lock the handset immediately after each use.

### **Safety stop position**

The safety stop position is the position the bed will stop at when lowering the bed using button 6. The mattress platform height will be approximately 20cm. To use the floor level function, refer to Section 11.

### **Handset lockout function**

To prevent unauthorised or accidental operation the handset can be locked out. Press button 1 and button 12 together for 3 seconds; the handset will beep slowly to indicate that the handset is locked.

To unlock the handset, press button 1 and button 12 together for 3 seconds; the handset will beep quickly to indicate that the handset is unlocked.

### **Reset to flat-and-level function**

The bed can be returned to a position where the mattress platform is level by pressing and holding button 7 until the bed stops moving.

### **Trendelenburg function**

To set the mattress platform in the Trendelenburg position (head down), press buttons 8 and 10 together.

To set the mattress platform in the Reverse Trendelenburg position (head up), press button 9.

## **11. Floor-level Function -----**



### **WARNING**

Extreme care must be taken when using the floor-level function.

Always check for any entrapment risk and obstructions under the bed before and during use of the floor-level function.

Keep children and pets away from the bed unless supervised by an adult.

Patients, users and operators must be risk assessed and made aware of the risks to themselves and those around before using the floor-level function of this bed.

Beware of trip hazard when the bed is in the floor-level position.

The floor-level function will lower the mattress platform to floor level. The mattress platform height will be 3.9in.

To lower the bed to the floor-level position:

1. Check underneath the bed to make sure there are no obstructions or entrapment risks.
2. When lowering the bed, make sure the user or patient keeps hands and legs away from the edge of the mattress.
3. Press button 6 to lower the bed until it reaches the safety stop position (approx. 8in).
4. Press buttons 6 and 8 together. The bed will now move down to the floor-level position. The bed will move slower between the safety stop position and the floor-level position.

*NOTE: If either of the buttons are released, the bed will stop moving immediately.*

5. When the bed has reached the floor-level position, store the handset in a safe place.
6. To raise the bed from the floor-level position, press button 5.

## 12. Length Adjustment-----

The FloorBed 6 can be extended by 3.9in at the foot end. Refer to section 15 for the appropriate length setting for the mattress being used.

*NOTE: The bed is only extendable at the foot end.*

To extend the bed:

1. Undo the bolts shown in Figure 12.1 on each side of the bed at the foot end and retain the bolts and washers.

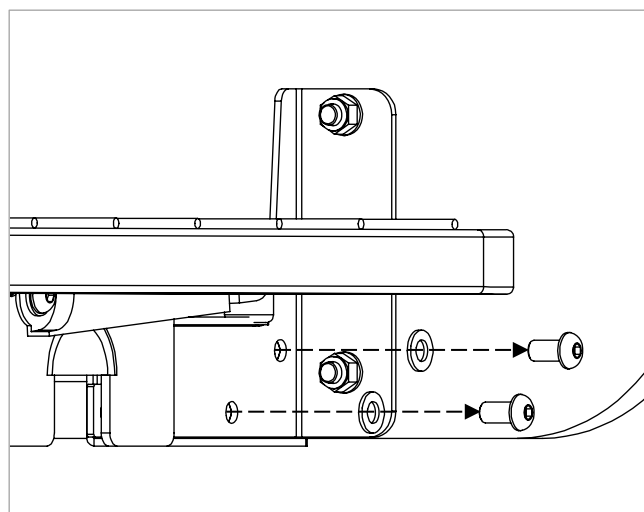

Figure 12.1

2. Slide the footboard outwards as Figure 12.2 until the holes in the footboard bracket marked 'Extended' in Figure 12.3 line up with the mounting holes on the bed frame.

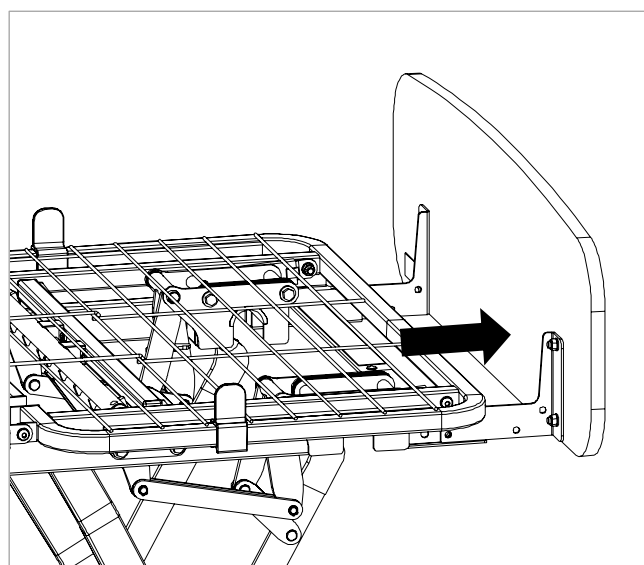

Figure 12.2

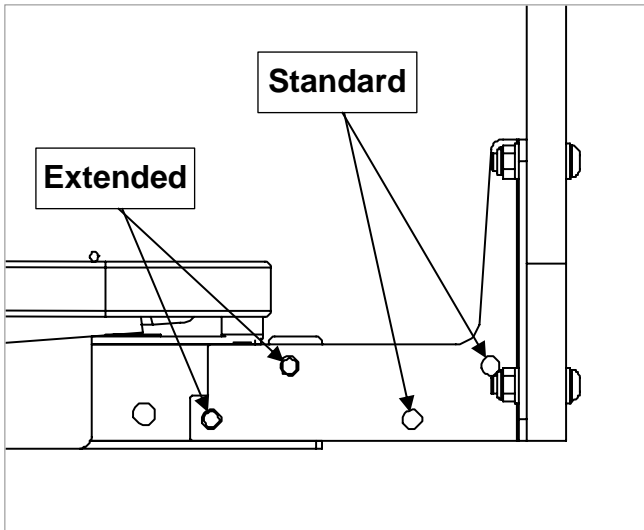

Figure 12.3

3. Secure the footboard with the bolts and washers in the extended position as shown in Figure 12.4.

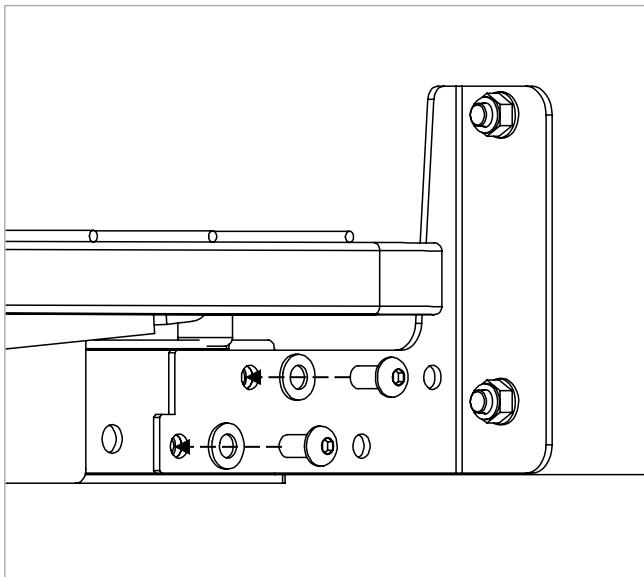

Figure 12.4

Note: if side panels are fitted, you will need to purchase longer side panels before the bed can be extended.

### 13. Functionality Check-----



#### WARNING

Functionality check **MUST** be carried out by suitably trained and qualified personnel.

Check for obstructions around, above and below the bed frame and position the bed so that it can operate through the full height range without any chance of obstruction or entrapment.

Always engage the brakes when the bed is stationary or left unattended.

Using the handset, test all bed functions and check all cables for risk of crushing. Refer to Section 10 - Bed Controls and Indicators:

1. Raise the bed to full height (button 5)
2. Lower the bed until it stops at the safety stop position (button 6)
3. Lower the bed to the floor-level position (buttons 6 & 8 pressed together)
4. Check all cables for risk of crushing.
5. Raise and lower the backrest (buttons 1 & 2).
6. Raise and lower the legrest (buttons 3 & 4).
7. Check the Reverse Trendelenburg function (head up, feet down) (button 9).
8. Check the Trendelenburg function (head down, feet up) (buttons 8 & 10 pressed together).
9. Check the correct function of the castors and brake control.

## 14. Using the Castor Brakes -----

Care must be taken to make sure the castor brakes are always locked when the bed is in use, being assembled or dismantled, so that the bed does not move accidentally.

### Central castor brake

1. To lock the brake, press firmly downwards on the side of the pedal with the red label as shown in Figure 14.1 until it locates.

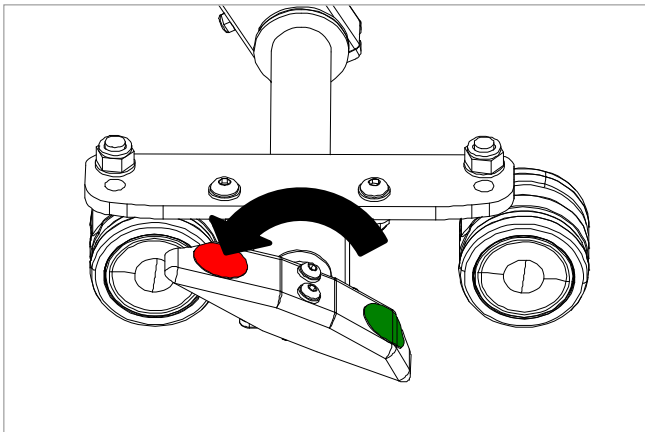

Figure 14.1

2. To unlock the brake, press firmly downwards on the side of the pedal with the green label as shown in Figure 14.2 until the brake releases.

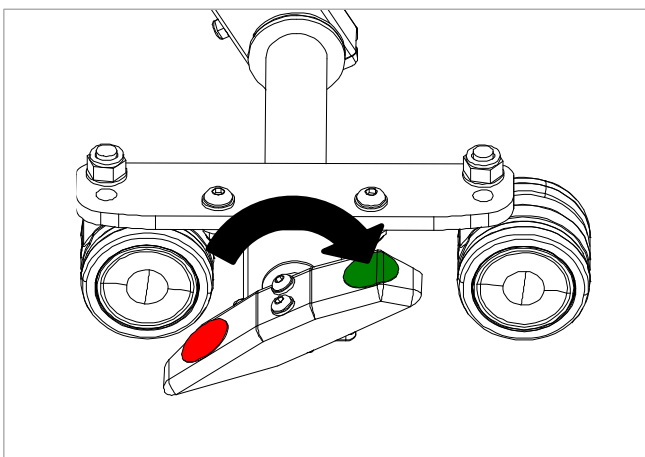

Figure 14.2

## 15. Mattress Selection -----



### WARNING

Incompatible mattresses can create hazards and entrapment risks. Read instructions for use.

The distance from the top of the un-compressed mattress to the top of the siderail, if fitted, must always be 8.7in or greater.

Bed extension **MUST** be carried out by suitably trained and qualified personnel.

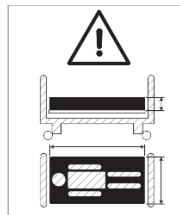

Please contact Accora for compatible mattresses.

Incompatible mattresses can create hazards and entrapment risks.

All mattresses must be fitted and used in accordance with the mattress manufacturer or supplier's instructions.

The following table shows the correct bed settings for the different mattress sizes that can be fitted.

If the width adjustment kit (WDEX-0-FL6-000) is fitted, a mattress of width 42in may be used. Refer to the width adjustment kit instructions for use for more information.

Mattress size	Width adjustment kit WDEX-0-FL6-000	Length setting (See section 12)
80in x 36in Standard length / standard width	Not required	Standard setting at foot end
84in x 36in Extended length / standard width	Not required	Extended setting at foot end
80in x 42in Standard length / extended width	Required	Standard setting at foot end
84in x 42in Extended length / extended width	Required	Extended setting at foot end

## 16. Moving and Repositioning -----



### WARNING

Moving or repositioning **MUST** be carried out by suitably trained and qualified personnel.

All functions **MUST** be tested and approved by a competent person after moving or repositioning.

Do not move the bed in the floor-level position.

Do not move or reposition the bed with service user or patient on the bed.

Do not move the bed when the power supply is plugged in to the mains supply socket.

When moving or repositioning the bed, disconnect the power supply, secure the power cable on the bed and do not allow cable loops to get snagged or caught.

Take care when moving the bed over door thresholds.

1. Ensure the bed is at the safety stop position (see Section 10).
2. Disconnect the power supply cable.
3. Secure the handset, power supply and all cables to prevent damage.
4. Unlock the castors (See Section 14) and move the bed as required.
5. When the bed has been moved or repositioned, lock all the castors.
6. Reconnect the power supply cable and perform full functionality check as described in Section 13.

## 17. Cleaning & Disinfection -----



### WARNING

The bed must be disconnected from the power supply when being cleaned or disinfected.

All functions **MUST** be tested and approved by a competent person after cleaning or disinfection.

The bed **MUST** be cleaned and disinfected before re-using the bed for a different patient

### Cleaning Information:

Cleaning must be carried out at regular intervals as determined by the facility. The bed must be cleaned between patients.

It is expected that cleaning the bed as described will take 15-30 minutes.

To disinfect the bed, only use detergents designed for use in healthcare. Do not use abrasives, scourers or other materials that could damage the coating. Do not use corrosives, caustics or strong acids. Do not use detergents that could alter the structure or behaviour of the plastics (petrol etc.).

Clean by wiping with a damp cloth.

The bed is not designed for maintenance in automatic bed washers or for cleaning with pressurised water, spraying, showering or steam cleaning.

Accora cannot be liable for any damage or risk of damage if inappropriate cleaning or disinfectant agents are used.

**Cleaning Procedure:**

1. Remove all accessories, mattress etc.
2. Adjust the mattress platform to the highest position and adjust the position of the backrest and legrest to provide access for cleaning all the platform parts.
3. Disconnect the bed from the power supply.
4. Move the bed to where cleaning will take place and lock the bed castors.
5. Clean as described in the “Cleaning Information” section above.

**18. Troubleshooting -----**



**WARNING**

Troubleshooting **MUST** be carried out by suitably trained and qualified personnel.  
 Do not attempt to open any electrical part enclosures.  
 Do not attempt to repair any electrical parts.  
 All functions **MUST** be tested and approved by a competent person after troubleshooting

The control box has an indicator light which may be used for troubleshooting. The indicator light can be seen by removing the mattress and looking through the mattress platform at the control box as shown in Figure 17.1

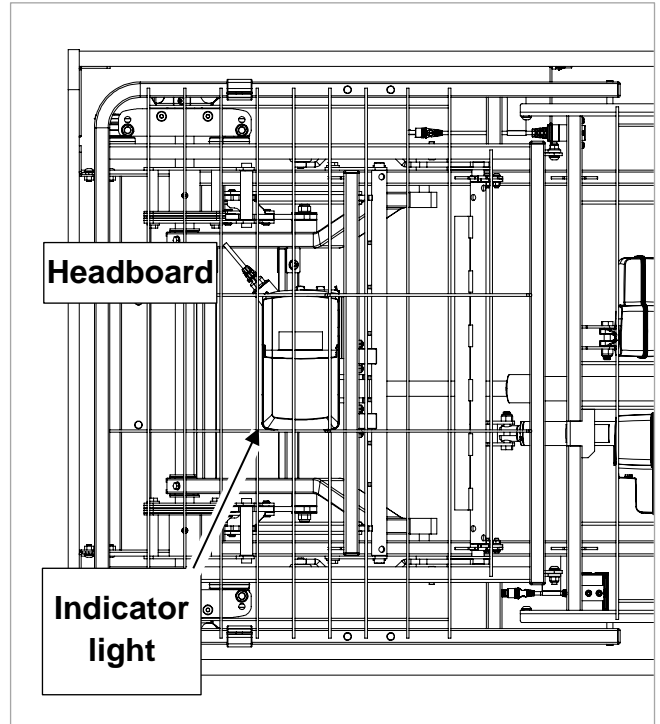

Figure 17.1

	Possible solution(s)
The bed makes a beeping sound when a button is pressed on the handset, but nothing happens.	Unlock the handset as described in section 10.
The bed is not functioning. Control box indicator light is not lit.	Check that the bed is connected to a mains power supply and the socket is switched on. Check mains power supply connection to control box.
The bed is not functioning. The control box indicator light is green but does not change to orange when a handset button is pressed.	Check connection of handset to control box.
The bed does not function as expected.	Reset the bed by pressing and holding buttons 3 and 4 shown on Figure 10.1 on the handset until the beeping sound stops.

If the bed still does not function correctly, contact Accora for further advice.

## 19. Storage -----

For problem-free storage we recommend:

1. Disconnect the bed from the electrical supply.
2. Secure the power cable to the bed to prevent any damage to the cable while moving.
3. Remove the accessories.
4. Wrap the bed and accessories or cover them so that the coating and plastic parts are not damaged.
5. Bed should be stored in a temperature between -10°C and +50°C.
6. Bed should be stored in a relative humidity (non-condensing) between 20% and 80%.

## 20. Daily Inspection -----

Daily visual inspection is strongly recommended and may be carried out by caregiver, user or other person.

The following checks must be carried out:

1. Does the bed operate as per its intended purpose without unexpected noise or motion?
2. Are there any signs of abuse or excessive wear?
3. Are all fixtures and fittings tight and secure?
4. Does the bed frame appear stable and secure?
5. Are all accessories fitted in line with the accessory manufacturer or accessory supplier's instructions?
6. Are all the castor brakes in the locked position?
7. Are all electrical cables (including accessories, e.g. mattress air pump) secured and routed to prevent damage?
8. Does the handset lock function work correctly? (See Section 10)
9. Does the bed stop at the safety stop position? (See Section 10)
10. Is the area around, above and below bed clear of possible obstruction?
11. Is there any risk of entrapment or patient injury?
12. Are any electrical cables pinched, crushed or damaged in any way?

If any damage, performance issue or cause for concern is noted during this inspection the bed should be disconnected from the power supply immediately, withdrawn from service and appropriate steps should be taken.

## 21. General Maintenance-----



### **WARNING**

Maintenance **MUST** be carried out by suitably trained and qualified personnel.

All functions **MUST** be tested and approved after maintenance by suitably trained and qualified personnel.

Only power supply supplied with bed may be used.

Do not carry out maintenance with service user or patient on the bed.

The power supply cord may be replaced by suitably trained and qualified personnel. Ensure that the replacement power supply cord is attached to the bed frame in the same way as the original power supply cord. Operate the bed through all its functions to ensure the power supply cord is not trapped in the mechanism.

For information on service and repair of the FloorBed 6, refer to the service manual, SER-FL6-001EN. Repairs to the bed must be carried out by suitably trained and qualified personnel.

## 22. Guarantee -----

The FloorBed 6 has a warranty period of 2 years on the electrical components and accessories, and 10 years on the frame.

## 23. Disposal-----

In the event of the disposal of materials from the bed, end-of-life parts must be disposed of in accordance with current environmental regulations.

## 24. EMC Statement -----

### Guidance and manufacturer's declaration-electromagnetic emissions

The bed is intended for use in the electromagnetic environment specified below.  
 The customer or the user of the bed should assure that it is used in such an environment.

Emission test	Compliance	Electromagnetic environment-guidance
RF emissions CISPR 11	Group 1	The bed uses RF energy only for its internal function. Therefore, its RF emissions are very low and are not likely to cause any interference in nearby electronic equipment.
RF emissions CISPR 11	Class B	The bed is suitable for use in all establishments, including domestic establishments and those directly connected to the public low-voltage power supply network that supplies buildings used for domestic purposes.
Harmonic emissions IEC 61000-3-2	Class A	
Voltage fluctuations /flicker emissions IEC 61000-3-3	Compliance	

**Guidance and manufacturer's declaration-electromagnetic immunity**

The bed is intended for use in the electromagnetic environment specified below.

The customer or the user of the bed should assure that it is used in such an environment.

<b>Immunity test</b>	<b>IEC 60601 test level</b>	<b>Compliance level</b>	<b>Electromagnetic environment-guidance</b>
Electrostatic discharge(ESD) IEC 61000-4-2	+ 6 kV contact + 8 kV air	+ 6 kV contact + 8 kV air	Floors should be wood, concrete or ceramic tile. If floors are covered with synthetic material, the relative humidity should be at least 30%
Electrical fast transient/burst IEC 61000-4-4	+ 2kV for power supply lines + 1kV for input/output lines	+ 2kV for power supply lines Not applicable	Mains power quality should be that of a typical commercial or hospital environment.
Surge IEC 61000-4-5	+ 1kV line(s) to line(s) + 2kV line(s) to earth	+ 1kV differential mode Not applicable	Mains power quality should be that of a typical commercial or hospital environment.
Voltage Dips, short interruptions and voltage variations on power supply input lines IEC 61000-4-11	<5% UT(>95% dip in UT) for 0,5 cycle 40% UT(60% dip in UT) for 5 cycles 70% UT(30% dip in UT) for 25 cycles <5% UT(>95% dip in UT) for 5 s	<5% UT(>95% dip in UT) for 0,5 cycle 40% UT(60% dip in UT) for 5 cycles 70% UT(30% dip in UT) for 25 cycles <5% UT(>95% dip in UT) for 5 s	Mains power quality should be that of a typical commercial or hospital environment. If the user of the bed requires continued operation during power mains interruptions, it is recommended that the bed be powered from an uninterruptible power supply or a battery.
Power frequency(50, 60 Hz) magnetic field IEC 61000-4-8	3 A/m	3 A/m	The bed power frequency magnetic fields should be at levels characteristic of a typical location in a typical commercial or hospital environment.

NOTE UT is the a.c. mains voltage prior to application of the test level.

## Guidance and manufacturer's declaration-electromagnetic immunity

The bed is intended for use in the electromagnetic environment specified below.

The customer or the user of the bed should assure that is used in such and environment.

Immunity test	IEC 60601 test level	Compliance level	Electromagnetic environment-guidance
Conducted RF IEC 61000-4-6	3 Vrms 150 KHz to 80 MHz	3 Vrms	<p>Portable and mobile RF communications equipment should be used no closer to any part of the bed including cables, than the recommended separation distance calculated from the equation applicable to the frequency of the transmitter.</p> <p>Recommended separation distance:  <math>d = 1,2 \sqrt{P}</math>  <math>d = 1,2 \sqrt{P}</math> 80MHz to 800 MHz  <math>d = 2,3 \sqrt{P}</math> 800MHz to 2,5 GHz</p> <p>Where P is the maximum output power rating of the transmitter in watts (W) according to the transmitter manufacturer and d is the recommended separation distance in metres (m).</p> <p>Field strengths from fixed RF transmitters, as determined by an electromagnetic site survey, a should be less than the compliance level in each frequency range                      Interference may occur in the vicinity of equipment marked with the following symbol:</p> 
Radiated RF IEC 61000-4-3	3 V/m 80MHz to 2,5 GHz	3 V/m	

NOTE1 At 80 MHz and 800 MHz, the higher frequency range applies.

NOTE2 These guidelines may not apply in all situations. Electromagnetic propagation is affected by absorption and reflection from structures, objects and people.

a	<p>Field strengths from fixed transmitters, such as base stations for radio (cellular/cordless) telephones and land mobile radios, amateur radio, AM and FM radio broadcast and TV broadcast cannot be predicted theoretically with accuracy. To assess the electromagnetic environment due to fixed RF transmitters, an electromagnetic site survey should be considered. If the measured field strength in the location in which the bed is used exceeds the applicable RF compliance level above, the bed should be observed to verify normal operation. If abnormal performance is observed, additional measures may be necessary, such as re-orienting or relocating the bed.</p>
b	<p>Over the frequency range 150 kHz to 80 MHz, field strengths should be less than 3 V/m.</p>

**Recommended separation distance between portable and mobile RF communications equipment and the bed.**

The bed is intended for use in an electromagnetic environment in which radiated RF disturbances are controlled.

The customer or the user of the bed can help prevent electromagnetic interference by maintaining a minimum distance between portable and mobile RF communications equipment (transmitters) and the bed as recommended below, according to the maximum output power of the communications equipment.

Rated maximum output power of transmitter W	Separation distance according to frequency of transmitter m		
	150 kHz to 80 MHz $d = 1,2\sqrt{P}$	80 MHz to 800 MHz $d = 1,2\sqrt{P}$	800 MHz to 2,5 GHz $d = 2,3\sqrt{P}$
0,01	0,12	0,12	0,23
0,1	0,38	0,38	0,73
1	1,2	1,2	2,3
10	3,8	3,8	7,3
100	12	12	23

For transmitters rated at a maximum output power not listed above, the recommended separation distance  $d$  in metres (m) can











be estimated using the equation applicable to the frequency of the transmitter, where  $p$  is the maximum output power rating of



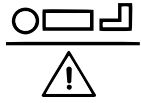
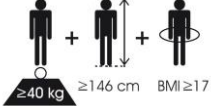

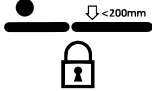

the transmitter in watts (W) according to the transmitter manufacturer.

NOTE1 At 80 MHz and 800 MHz, the separation distance for the higher frequency range applies.

NOTE2 These guidelines may not apply in all situations. Electromagnetic propagation is affected by absorption and reflection from structures, objects and people.

## 25. Table of Symbols

	General warning
	General caution
	Complies with the European Medical Device Regulation 2017/745
	Model number
	Serial number
	Maximum patient weight
	Physical description of an adult
	Manufactured date
	Manufacturer
	Medical Device in accordance with EU Medical Device Regulation 2017/745
	Floor-level function warning
	Ensure the side rails are compatible with the bed before fitting

	Warning, use compatible mattresses only		
	Safe working load (SWL) – Maximum weight the bed can safely carry including the patient, mattress and accessories fitted		
	Refer to instructions for use before using the product		
	The B symbol indicates this product has a degree of protection against electric shock for type B equipment		
	Do not dispose of in household waste		
	Degree of protection against electric shock: Class II Double Insulated		
	For indoor use only		
<p><b>IPX6</b></p>	Degree of protection against liquid ingress		
<table border="1" data-bbox="248 1391 453 1458"> <tr> <td data-bbox="248 1391 349 1458"><b>EC</b></td> <td data-bbox="349 1391 453 1458"><b>REP</b></td> </tr> </table>	<b>EC</b>	<b>REP</b>	EC Representative
<b>EC</b>	<b>REP</b>		

## 26. Contact Details

---

	UK and Rest of World	USA
Address	Accora Ltd. Charter House Barrington Road Orwell Cambridge SG8 5QP UK	Accora Inc. 9210 Corporate Blvd. Suite 120 Rockville MD 20850 USA
Telephone	+44 (0)1223 206100	+1 301-560-2400
Email	info@accora.care	information@accora.care
Website	www.accora.care	

*This page intentionally left blank*

# Accora



Accora  
Barrington Road  
Orwell  
Cambridge  
SG8 5QP  
United Kingdom

T: +44 (0)1223 206100  
[info@accora.care](mailto:info@accora.care)  
[www.accora.care](http://www.accora.care)

IFU-FL6-001US Rev 01