

# carilex<sup>®</sup>

## **Envelop**

Anti-Decubitus Air Alternating Mattress Replacement  
System

Instructions for Use

The logo consists of the letters 'H' and 'R' in a large, grey, serif font. A blue ampersand (&) is positioned between the two letters, overlapping them.





## About This Document

Congratulations and thank you for purchasing this high quality anti-decubitus system.  
Please read these Instructions carefully before use and observe the safety instructions and the requirements for the operation and maintenance of the device.

Device identification

**Identification Details of the Device**

These Instructions for Use are intended exclusively for devices with the following specification:  
Device name: Envelop System  
The serial number is shown on the label on the rear panel of the power unit and on the tag sewn on the mattress.

Validity of the documentation

**Details of the Device Documentation**

This manual describes the Envelop System. It is part of the device documentation. Do not pass this device to a third party without these Instructions for Use.  
For the confirmation of the up-to-date status of the documentation, the end page of the Instructions for Use is marked by edition version.

Subject to change

The contents of the Instructions for use can be changed by the manufacturer at any time without prior notice.

Translations

For translations into languages other than English, the English version of these Instructions for Use is authentic.

Copyright

The contents of these Instructions for Use are protected by copyright. The resulting rights, in particular, the reprinting, the photomechanical or digital processing or copying of the contents or any part thereof, are only permitted with the written approval of Carilex Medical, Inc. This provision shall not affect the reproduction for internal use.

## About This Document



### **Information on the Manufacturer's Representative**

Carilex Medical, Inc.  
No. 77, Keji 1st Rd., Guishan District, Taoyuan City(33383),  
Taiwan(R.O.C)

**EC REP**  
Distributor

### **EU Representative:**

Carilex Medical GmbH  
Hanauer Landstraße 291 B60314 Frankfurt am Main Germany  
Tel:+49 69710475168  
Email: [info@carilexmedical.com](mailto:info@carilexmedical.com)

Sales and  
service

### **For Support or Complaints**

In the event of a complaint, or if you have any questions about the use of the device or a need for spare parts, please contact the supplier, that delivered the device to you or your patients.

carilex®

## Table of Contents

<b>1</b>	<b>Important Notes for Safe Use</b>	<b>5-11</b>
1.1	Designation of the Groups of Individuals	5
1.2	Notes for the Users	6
1.2.1	Instruction	6
1.2.2	Handing Over the Device	6
1.2.3	Maintenance and Installation	6
1.2.4	Information and Test Obligation of the User	6
1.3	Procedures for Accident Prevention	7
1.3.1	Procedures for Handing Over the Device	7
1.3.2	Qualification Requirements Hygiene Staff	7
1.3.3	Availability of the Instructions for Use	7
1.4	Purpose of the Device	8
1.4.1	Intended Use	8
1.4.2	Attention	8
1.4.3	EMC Compliance Statement	9
1.5	Warranty	9
1.6	Safety Information and Symbols of These Instructions for Use	10
1.6.1	Identification of Risks of Injury	10
1.6.2	Identification of Material Damage	10
1.6.3	Identification of Additional Information	10
1.6.4	Additional Symbols to the Safety Information	11
<b>2</b>	<b>Security Norms</b>	<b>12-13</b>
2.1	Correct Use of the System	12
2.2	Advice	13
<b>3</b>	<b>Delivery and Storage</b>	<b>14-15</b>
3.1	Packaging	14
3.2	Delivery Control	14
3.3	Storage and Transport	14
<b>4</b>	<b>Device and Functional Description</b>	<b>15-16</b>
4.1	Device Description	15
4.2	Operation and Functional Test	16

## Table of Contents

<b>5 Features</b>	<b>17-21</b>
5.1 Control Panel	17
5.2 Side Panel	20
5.3 Rear Panel	21
<b>6 System Installation, Operation, Transfer and Transport of Patient</b>	<b>22-23</b>
6.1 System Installation	22
6.2 Operation	22
6.3 Transfer and Transport of Patient	23
<b>7 Application</b>	<b>24</b>
7.1 Preparing the Application	24
7.1.1 Inflating the Mattress	24
7.1.2 Patients Positioning	24
<b>8 Cleaning and Disinfection</b>	<b>25-27</b>
8.1 Cleaning	26
8.2 Disinfection	27
<b>9 Care and Maintenance</b>	<b>28</b>
9.1 Inspection	28
9.2 Maintenance of Air Filter	28
9.3 Maintenance of Battery Pack	28
<b>10 Troubleshooting</b>	<b>29</b>
<b>11 Technical Data</b>	<b>30</b>
<b>12 EMC Declaration</b>	<b>31-32</b>
<b>13 Safety Precautions for Li-Ion Battery Pack</b>	<b>33</b>

# 1 Important Notes for Safe Use

Named groups  
of persons

## 1.1 Designation of the Groups of Individuals

The named groups of persons in these Instructions for Use are as follows.

### Operators

An operator (surgical supplier, health insurance, clinic, etc.) is any legal person, who owns Envelop System and uses it, or on whose behalf the device is in use. The operator is responsible for providing a safe device and to instruct the user properly on the operation and safe use of the device.

### Users

Users are people who are entitled, due to their training or a corresponding instruction to:

- Operate the Envelop System
- Supervised patients using the device for therapy or care purposes.

Users are fully responsible for the safe and correct use of the device. A review of the functions has to be carried out and the proper condition of the device has to be checked and confirmed by the user before each use or transfer for use.

### Professionals

The authorized persons are skilled personnel, who are as a rule, the employees of the operator and who:

- Have acquired their knowledge through professional training in the medical-technical field,
- Carry out their activity on the basis of professional work experience and instructions according to safety-related regulations and are able to detect possible hazards during work.

In countries in which the pursuit of an activity in the medical-technical area is certified, the classification as qualified personnel is subject to appropriate approvals.

### Patients

Patients in the sense of these instructions are persons in need of care, who use the Envelop System for therapy or care purposes.

# 1 Important Notes for Safe Use

## 1.2 Notes for the Users

Note that the Envelop System should only be used by persons who have been trained in the operation and the intended use of the device.

Training on the device

### 1.2.1 Instruction

The training of users on how to use the device must be carried out by the qualified personnel of the operator using the device. If the device is approved for use, then it is obligatory to comply with the instructions of this guidance

Device approval

### 1.2.2 Handing Over the Device

The device may only be used, if the operator has released it for therapeutic or care use and if the hand over was carried out properly and under the supervision of authorized personnel.

After the hand over the users are fully responsible for the safe and dedicated use of the device.

### 1.2.3 Maintenance and Installation

The maintenance and/or repair of the equipment or parts may only be carried out by an authorized service agent.

Obligation of the user

### 1.2.4 Information and Test Obligation of the User

Read these Instructions for Use carefully before the first use of the device. This will allow you to experience all the benefits that the device offers and avoid possible personal injury and property damage.

A review of the functions has to be carried out and the proper condition of the device has to be confirmed by the user before each use or transfer for use by patients.

In case of specific issues, which are not covered in enough details in these Instructions for Use please contact the supplier or operator for further guidance.

# 1 Important Notes for Safe Use

## 1.3 Procedures for Accident Prevention

The Envelop System is made according to the current state of the art technology and is reliable. However, hazards may arise during the use of this device if it is operated by untrained personnel or it is not operated as described in these Instructions for Use.

### 1.3.1 Procedures for Handing Over the Device

In order to comply with the regulations of accident prevention and to prevent accidental damage, the following procedural guidelines are to be followed when handing over the device:

- The initial start-up of the device, as well as the hand over to the user must be carried out by an authorized personnel assigned by the operator.
- After completion of the training, it must be documented that the user has understood the operation and use of the device for therapy or care purposes.

Hygiene  
measures

### 1.3.2 Qualification Requirements Hygiene Staff

The nature of hygiene measures is determined by the use environment of the device.

- If the device is used in clinical areas (e.g. in hospitals, clinics, nursing home, elderly homes etc.) the cleaning and disinfection must be carried out on the product or parts only by appropriately qualified personnel, who are familiar with the relevant hygiene regulations.
- When using the device in non-clinical areas the users or trained cleaning personnel can perform cleaning of the device.

Obligation  
to provide  
information

### 1.3.3 Availability of the Instructions for Use

The Instructions for Use are an integral part of the device and must be stored in a place so that the safety instructions and other important information are accessible at any time and can reviewed by the users. Do not pass the device to a third party without these Instructions for Use. Using the edition version as a guide always ensures that a current and valid Instructions for Use document is supplied with the device.

# 1 Important Notes for Safe Use

## 1.4 Purpose of the Device

To ensure the security of patients and users, the device may only be used for its intended use.

Intended use

### 1.4.1 Intended Use

The therapeutic air alternating mattress / cushion system is designed for patients who endure pressure ulcer and potential patients who wish to reduce the likelihood of pressure ulcer. The device is intended to treat and prevent pressure ulcers by facilitating blood circulation and decreasing pressure of each tissue's contact area.

Contraindications:

Certain patient conditions are not suitable for using this type of device such as fracture of instable vertebrae and illness of instable vertebrae. Always consult a physician or health professional before using this device. The use of this system does not replace the regular repositioning, monitoring, and nursing of the patient.

Attention

### 1.4.2 Attention

Always consult a physician or health professional before using the Envelop System. Any and all applications outside of the conditions specified above are regarded as unapproved. The user and the operator respectively are exclusively liable for any damage resulting from the unapproved use.

# 1 Important Notes for Safe Use

## EMC notices

### 1.4.3 EMC Compliance Statement

Use of accessories and/or cables other than those specified or provided by the manufacturer of the SR388 may negatively affect EMC performance.

- Power cord set: It is non-shielding, and the typical length of power cord is 4.5m max. molded with IEC 60320 C13 connector.
  - For EU:VDE Certified AC Plug, Cord Type H05VV-F, 1mm<sup>2</sup> x 3C
  - For US: hospital Grade AC Plug, Cord Type SJT, 18AWG x 3C
  - Safety approved AC Plug, Cord Type H05VV-F 3 x 1mm<sup>2</sup>
- Use of the SR388 adjacent to or stacked with other RF communications equipment (including antennas) should be avoided and to be used no closer than 30cm to any part of the SR388, including cables specified by the manufacturer because it could result in improper operation.
- Medical Equipment Immunity Performance Criteria Unacceptable Operating Conditions:
  - a. Component failures or error of display numerical value.
  - b. Change or failure in programmable parameters if any.
  - c. Initiation of any unintended operation or false audible indicator.
  - d. Cessation, change or interruption of any intended operating mode.

## Warranty terms and conditions

### 1.5 Warranty

The supplier shall ensure the safety and the correct functioning of the Envelop System only under the following conditions:

- The device is used for the intended use and maintained only in accordance with the information provided by these Instructions for Use.
- Only original spare parts or accessories approved by the manufacturer are used.
- No structural changes are made to the device.
- Inspections and maintenance work are carried out by certified personnel according to the specified time intervals.

# 1 Important Notes for Safe Use

## 1.6 Safety Information and Symbols of These Instructions for Use

The safety instructions in this Instructions for Use are marked with symbols and key words. Signal words like WARNING, CAUTION or ATTENTION designate the classification of the risk.



### 1.6.1 Identification of Risks of Injury

#### **WARNING**

Means a hazardous situation, which may lead to death or severe injury if it is not avoided.



#### **CAUTION**

Means a hazardous situation, which may lead to minor or severe injury if it is not avoided.



### 1.6.2 Identification of Material Damage

#### **ATTENTION!**

Describes a situation that could lead to property damage if it is not avoided.



### 1.6.3 Identification of Additional Information

#### **NOTE!**

Means application tips and useful information.

# 1 Important Notes for Safe Use

## 1.6.4 Additional Symbols to the Safety Information

Additional symbols to the safety information are those listed below



Machine Wash Warm : Max. 60°C



Machine Wash Warm : Max. 71°C



Do Not Bleach



Do Not Iron



Do Not Dry Clean



Hang to Dry



Tumble Dry Medium - Gentle Cycle



Consult Instructions for Use



Declaration of Conformity to Medical Device Directive



US NRTL - SGS Listed Mark



Type BF Applied Part



Protective Earth



Waste Electrical and Electronic Equipment (WEEE Logo)



Manufacturer



Date of Manufacture



Caution (ISO 7000-0434A)



Catalogue Number



Authorized Representative in the European Community

IP21

Protected against ingress of solid foreign objects  $\geq 12.5\text{mm}$  diameter.  
Protected against vertically falling water drops.

**2****Security Norms****2.1 Correct Use of the System**

- (1) In order to guarantee the correct operation, ensure that the system is perfectly assembled and securely fasten the mattress with the specific straps to the bedframe. Make sure that the straps do not interfere with the bed movements.
- (2) Hang the power unit to the bed footboard using the specific hanger hooks and do not place any objects onto the power unit. Insert the power cord set into one of the two cable holders placed at each side of mattress base and fix by the press studs on the cable holder. Ensure that power cord set is not kinked or tighten up
- (3) Take care to ensure that the sheets are fitted correctly and not too tight to prevent hammocking. Too many layers of sheets could reduce the effects of the mattress system. Only breathable incontinence sleepers may be used.
- (4) Do not use the system in presence of live flame or sources of heat. The power unit extracts the air from the environment and despite its filter system, smoke can damage the internal components.
- (5) After each use the system must be disinfected and sanitized to prevent cross-infection.
- (6) Ascertain that the patient's weight does not exceed the weight allowed on the bedframe and the maximum therapeutic capacity of the anti-decubitus system.

**WARNING**

To avoid the risk of electric shock, the Envelop system must only be connected to a supply mains with protective earth.

---

## 2 Security Norms

### 2.2 Advice

- (1) Use the mattress within the bed side rails and assure that the space between the sides of the bedframe and the mattress is not big enough to insert the patient's head and neck. Neglecting this could cause serious injuries to the patient.
- (2) DO NOT open or dismantle the power unit if you are not a qualified technician. In case of problems, get in touch with the authorized assistance service.
- (3) Safety in the presence of inflammable anesthetic gases: the system is not AP/APG protected.
- (4) Use of the present system does not exclude repositioning and changes of posture of the patient wherever possible.
- (5) Environmental conditions for operating the Medical Electrical system:  
Temperature: 5°C to 40°C  
Humidity: 15% to 90%  
Atmospheric pressure: 700 hPa to 1060 hPa
- (6) The plug is used for disconnecting the device. Do not position the power unit in the way which will be difficult to disconnect.
- (7) No modification of this system is allowed.



#### CAUTION

- Ensure no points, springs protruding from mattress which may pierce the air cells.
  - DO NOT expose the Envelop System to the sunlight or the dusty environment.
  - May experience potential allergic reactions to accessible material used in the Envelop System.
  - Keep the Envelop System out of reach of children.
  - Skin irritation due to prolonged exposure to mattress or other accessories.
-

## 3 Delivery and Storage

### 3.1 Packaging

Envelop System is supplied in sturdy cardboard packaging. All packaging materials are recyclable and can be separated.

### 3.2 Delivery Control

Check immediately after delivery of the device:

- the completeness of the delivery
- the delivery status of the device

Envelop System is delivered with the following components:

- Power unit  
Including: Power unit x 1  
Power cord set x 1  
Lithium-ion battery pack x 1  
Instruction for Use x 1
- Mattress  
Including: Mattress x 1  
Coverlet x 1

If the delivery is incomplete or the device and/or the packaging are damaged, in particular in the case of damage caused by moisture or water, you should promptly inform the carrier, as well as the supplier.

### 3.3 Storage and Transport

Recommended environmental conditions for storage and transport:

- Ambient temperature: -25°C to 70°C
- Relative humidity: 0% to 90%



#### **ATTENTION**

Storage of the mattress

- Always roll the mattress, do not fold or bend.
  - Do not put or store with any sharp instruments or tool with sharp tips.
- 

For long-term storage the power unit should be covered with a dust protector.

## 4 Device and Functional Description

### 4.1 Device Description

#### Power unit

The power unit is used as the housing for the air source as well as control features:

- A control panel with buttons and lights to adjust the air system.
- Two hooks on the back to hang the power unit to a bedframe.
- A receptacle for an air filter on the rear panel.
- A quick coupling with three air outlets.
- A power cord set with a plug to connect the device into a wall socket.

#### Mattress

The mattress consists of multiple set of air cells which work in dynamic or static mode to envelop and redistribute pressure.

#### CPR for Standard Mattress

The CPR function is activated by a special valve with circular mechanism located on the right side of the mattress near the torso area. With a rapid maneuver opening the CPR valve, the mattress deflates in the torso area, allowing the Cardiopulmonary Resuscitation procedure to be activated within 15 seconds. The CPR valve, well-marked and built-in the side of the mattress prevents accidental opening, and it can be opened with a short clockwise rotation, with a single movement and with the use of one hand only.

#### CPR for Bariatric Mattress

The CPR function is activated by a special five ports CPR located on the right side of the mattress where the manifolds starts. With a rapid maneuver remove the CPR plug, the mattress deflates in the feet area, allowing the Cardiopulmonary Resuscitation procedure to be activated within 15 seconds. The CPR, well-marked and built-in the side of the mattress prevents accidental opening, and it can be opened by simply pull out the CPR plug, with a single movement and with the use of one hand only.

## 4 Device and Functional Description

### 4.2 Operation and Functional Test

To perform a functional test and at the initial start-up of the power unit take the following actions:

- Fully lay out the mattress. Both air hoses must be able to move easily without any kinks or pressure points.
- Make sure that the CPR valve is closed.
- Push in the quick coupling of the mattress firmly into the air outlet of the power unit.
- To disconnect mattress from power unit, simply just press the buttons on the coupling and pull.
- For function test details, please refer to Chapter 5 Features, please make sure all functions work normally before use.

#### Turning on the power unit



#### **Electric shock!**

Touching live parts can result in a death or serious injury by an electric shock. Check for damage of the plug and the main power cable of the power unit before connecting.

- Damaged components may not be used for connection!

## 5 Features



### CAUTION:

Different mattress systems have different settings. Using the wrong setting may cause severe system failure and risk of harming patient.

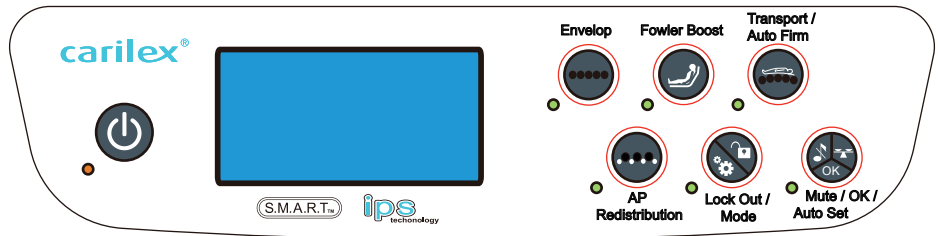

### 5.1 Control Panel



#### Identity Correct Mattress System

In order to provide better therapeutic effect to patients, Carilex offers multiple mattress systems including Standard and Bariatric size mattress. Therefore, it is important for the user to identify and select the correct setting on the power unit corresponding to the mattress system that is being used.

How to select function on the control panel of the power unit:

- (1) Plug the power cord into the proper wall socket, and switch on the rocker switch.
- (2) Turn on the power unit by press Power/Standby button. After the startup screen, press Lock Out/Mode button  to select the proper mattress type, Standard mattress with CPR valve near the torso area which support patient weights from 30 to 300Kg or Bariatric mattress without CPR valve near the torso area which support patient weights from 30 to 450Kg.
- (3) Press the Mute/OK/Auto Set button  to confirm the mattress setting selection.
- (4) The power unit will start the initialization of the system.
- (5) After finish the initialization and "SYSTEM READY" appears on the LCD screen, the system is ready for patient placement.

How to reset the mattress size:

- (1) Turn off the power unit by the power button on the panel foil and keep the rocker switch on.
- (2) After press the press power button again, the user could select the correct mattress size.

#### Power / Standby

When the rocker switch on the left side panel is switched on, the power unit is in standby mode and the orange LED will be lit. To turn on the power unit, press Power/Standby and the standby orange LED will be off.

#### Envelop (Static Mode)

Envelop Mode is the therapy in which all air cells maintain constant pressure support and maximize patient's contact area to redistribute pressure.

## 5 Features

### AP Redistribution (Dynamic Mode)

AP Redistribution Mode is a therapy mode in which air cells alternate in an A-B-A-B (odd and even number of air cell sets) pattern to relieve pressure and increase blood flow of the patient tissue. The 3 cells at the head are always excluded from the alternating. AP Redistribution mode will take 10 minutes to finish a complete cycle. For battery mode, the system will take 15 minutes to finish a complete cycle.

### Fowler Boost (Upright Mode)

Fowler Boost Mode is used to prevent patient from bottoming out in an upright position. Once fowler boost button is pressed, the green LED will light up and the symbol in LCD will display to indicate this mode is in operation.

### Transport / Auto Firm

By pressing the Transport/Auto Firm button, the system will rapidly bring the mattress to maximum steady pressure, which allows caregiver to perform the daily nursing procedures. A green LED will light up and the symbol in LCD will display to indicate this mode is in operation. Press this button again to stop this function or the system will automatically return to previous setting after 20 minutes.

### Mute / OK / Auto Set

This button would work for three functions. Mute function, it is used to turn off the audible indicator, otherwise the system will continue to sound for 1 minute and then stop for 4 minutes as a loop until the abnormality is solved. After mute the audible alert manually, it will not start beeping again, to avoid acoustic pollution, but the green LED will light and the mute symbol will display on LCD screen. The mute function is only operational when the audible alert is in effect.

The OK function is only functional when confirm the mattress type, Standard or Bariatric.

For Auto Set function, press the button for 3 seconds when the system auto setting is required. Then the system will re-detect the weight of patient and set the suitable pressure.

### Lock Out / Mode

When there is no operation after 3 minutes, system will automatically lock the control panel. The lock function can also be activated any time by pressing this button. All buttons will be locked except the Mute/OK/Auto Set button which allow user to mute audible alarm and the Transport/Auto Firm button. Simply press and hold the Lock Out button for 3 seconds to release the system from locking.

## 5 Features

For Mode function, press Lock Out/Mode to select the mattress type between Standard and Bariatric.

### **Language**

Envelop system is equipped with multi-languages setting including Espanol, Italiano, Deutsch, Francais and English. The default language of the system is English. To change the language, simply press Envelop and Fowler Boost button when the rocker switch is on and the system power is off. Use Envelop button to select the desired language, and press Mute/OK/Auto Set to confirm the selection.

### **Low Pressure Alert**

Both continuous audible and visual indicators on LCD display will be triggered to notify caregivers when the mattress has insufficient pressure. User may press mute button to turn off the audible alarm.

### **Battery Mode**

The system will switch to battery mode when abnormal power outages occur. While in battery mode, the system will change the alternating cycle time from the default 10 minutes to 15 minutes. Furthermore, if the system goes into low battery mode, it will switch to static mode to do further power saving.

### **Low Battery**

Once the battery contains less than 30% battery life, the light of LCD screen will switch off to prolong the operating time. The audible indicator will sound 15 times in 1 minute then stop for 4 minutes as circulation until power is returned. The users could press the mute button to turn off the audible alert.

### **CPC Detection**

Once the CPC connector of the mattress is disconnected from the air outlets, the system will trigger both audible alert and visual indicators on LCD display notify users. The users could press the mute button to turn off the audible alert.

### **Timer**

To view the total operating time of the power unit on the LCD display, ensure the rocker switch is switched on and the system power is off, then press both Fowler Boost and Transport/Auto Firm simultaneously.

## 5 Features

### 5.2 Side Panel

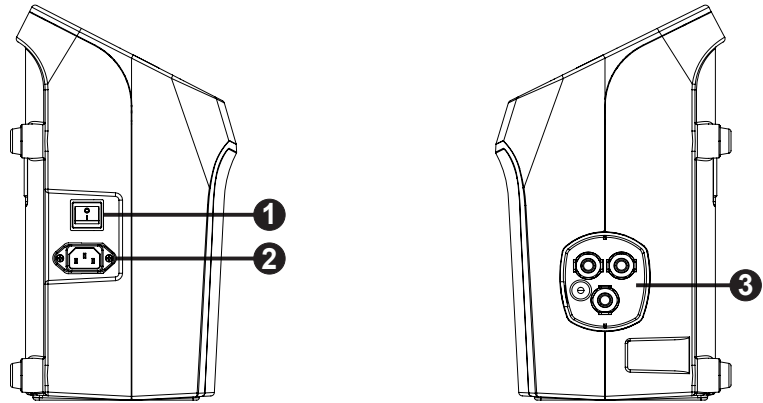

#### **Left Side Panel**

##### **Rocker Switch (1)**

Main power switch of power unit

##### **Power Receptacle (2)**

Three pin IEC 60320 C14 AC inlet to accept power cord set with C13 connector.

#### **Right Side Panel**

##### **CPC Connector (1)**

Quick couplings enable a rapid and firm connection between the mattress and the power unit.

## 5 Features

### 5.3 Rear Panel

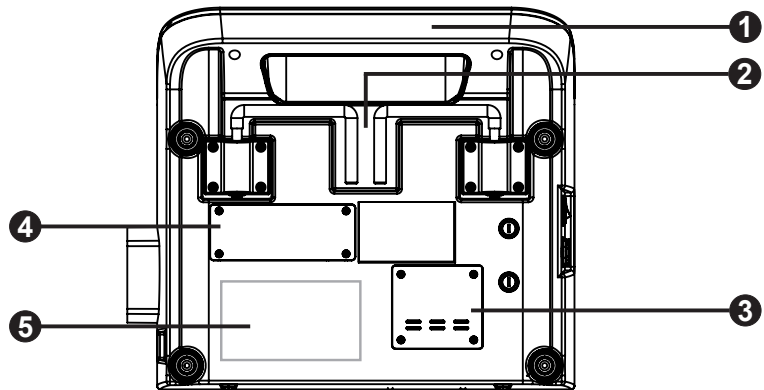

#### **Convenient Handle (1)**

It provides additional gripping surface for user to carry the power unit.

#### **Hanger Hooks (2)**

The hooks are designed to fit with multiple footboard widths.

#### **Air Filter and Filter Cap(3)**

We recommend inspecting and cleaning this filter as needed, depending on the environment the unit is being used. Failure to keep the filter clean will result in shorter life span of the unit and/or unit failure. When replacing, be sure to use Carilex standard filter to optimize the performance of the power unit.

#### **Battery Compartment(4)**

Allows for access for battery replacement. Also includes socket used for upgrading software/firmware. Remove the battery pack when unused for long periods of time.

#### **Specification ID Label (5)**

This label includes all the information for medical device and safety requirements.

## 6 System Installation, Operation, Transfer and Transport of Patient

### 6.1 System Installation

- (1) Remove the existing mattress.
- (2) Put the mattress on the structure of the bedframe with the logo at the foot of the mattress. Fasten the mattress with the use of the straps ensuring that the functions and movements of the bedframe are not limited before proceeding to the next step.
- (3) Hang the power unit at the foot of the bedframe with aid of the hanger hooks.
- (4) Push the quick coupling of the mattress firmly into the air outlet of the power unit.
- (5) Insert the power cord set into a wall outlet and switch on the rocker switch on the left side panel. Ensure that the cable is not in the way of the operators and the movement of the bedframe.
- (6) Choose the correct setting according to mattress type, Standard or Bariatric, on the control panel. Refer to Section 5.1 to identify the correct mattress system.



#### CAUTION

Different mattress systems have different settings. Using the wrong setting may cause severe system failure and risk of harming patient.

---

### 6.2 Operation

- (1) When the mattress is fully inflated and the "SYSTEM READY" appears on LCD, caregivers could position the patient on the mattress. Then the LCD screen will display "AUTO-SETTING", and during this time, the system is taking into account the mattress loading and adjust the appropriate system setting automatically.
- (2) Ensure to select the appropriate therapy mode according to the physician's decision.
- (3) **IMPORTANT:**  
Tucking in the coverlet too tensely significantly reduces the mattress's effectiveness.
- (4) **IMPORTANT:**  
Regardless of the type of coverlet that has been equipped to the mattress, ensure that the zipper of coverlet is affixed properly to the base of the mattress.
- (5) **WARNING!**  
Use the mattress within the boundaries of the bedframe and assure that the space between the sides of the bedframe and the mattress is not big enough to insert the patient's head and neck. Neglecting this could cause serious lesions to the patient.
- (6) Always turn off the power unit by using the power button and rocker switch. Failure to do so may cause machine malfunction.



## 6 System Installation, Operation, Transfer and Transport of Patient

### **Side Bolster Inflation and Deflation of Envelop Bariatric M-set**

Envelop Bariatric M-set has one extensional bolster located on each side of the core mattress. The bolster control valves are located at the foot end of the mattress underneath the flap on the top cover labeled "Control Valve". Each bolster has a separate control valve. The control valve located on the right side when facing the bed operates the right bolster; the control valve located on the left side when facing the bed operates the left bolster.

To Expand the width of the mattress:

Turn the bolster valve to the "HIGH" open position.

To Retract or deflate the bolster:

1. Locate the Control Valves for the side bolsters at the foot end of the mattress.
2. Turn the Control Valves to OFF.
3. Pull the yellow deflating strap on the side bolster, and allow the air in the side bolster to deflate.
4. Tighten the 5 black secure straps to help with deflating the bolsters and securing the bolsters in place.
5. Ensure to close the deflating cap that was pulled open in #3, once the bolsters are fully deflated.

### **6.3 Transfer and Transport of Patient**

#### **Transfer**

We recommend carrying out the transfer of the patient by having the system on Transport mode during transfer and ensure that the bed is well-positioned and steady.

#### **Transport**

For Envelop System, there are two ways to transport the patient:

1. Use the Transport/Auto Firm Mode to inflate the entire mattress to maximum pressure. After the mattress inflates to maximum pressure, power off the power unit and detach the CPC connector of the mattress from the air outlets of the power unit. Then insert the transport plug to CPC connector to retain air in the mattress and the mattress will stay inflated over 15 hours.

2. Unplug the power cord set from the wall outlet and the system will switch into battery mode, which will provide the power unit with power for approximately 2 hours for uninterrupted therapy.

Once the transportation phase is complete, reconnect the mattress to the power unit and follow Section 6.2 to resume normal operation. It is not necessary to move the patient during the re-inflating maneuver.

## 7 Application

Mandatory  
bedframe size

It is mandatory to select proper bedframe size for the Envelop System. Do not operate the Envelop System without safe installing of the mattress onto the bedframe. Make sure that the fixing of the mattress does not impede the adjustment mechanism of the bedframe.

Fix the mattress

### 7.1 Preparing the Application

- (1) Place the bedframe in the supine (flat) position.
- (2) Fix the mattress with the straps onto the bedframe.
- (3) Make sure that the CPR valve is closed.
- (4) Hang the power unit with the two hooks on to the footboard of the bedframe and check that the fixing is stable.
- (5) Connect the quick coupling of the mattress to the air outlet of the power unit. Make sure that the air hoses are routed without bending, kinks or pressure points.

#### 7.1.1 Inflating the Mattress

In preparation for the patient, the air cells should be inflated in advance by the power unit. The head cells should be fully inflated before patient placement to ensure that the head position is stable.

#### 7.1.2 Patients Positioning

Carry out the positioning of the patient in accordance with the local patient care guidance.

- The patient should be centered on the mattress, with equal distance from the left and right mattress's sides.
- The head of the patient should rest fully on the head air cells.



#### CAUTION

Pressure points on protective body areas!

During the application of the Envelop System, the skin of the patient must be regularly checked by medical and nursing staff and caregivers.



#### CAUTION

Loose power cord set may cause tripping and serious injury.

---

## 8 Cleaning and Disinfection

Check electrical components

In order to prevent cross-contamination, the cleaning and disinfection of the entire the Envelop System must be carried out between uses with different patients.



### WARNING

#### Electric shock!

Water has a high electrical conductivity. Contact with liquid under voltage can lead to a fatal electric shock. For the cleaning and disinfection operations:

- Turn off the power unit by power button and rocker switch.
- Unplug the power cord set from the power socket.



### CAUTION

#### Health hazard!

The contact with contaminated cleaning fluids can cause infections. Disinfectants can contain harmful substances.

Please follow these Instructions for Use of the manufacturer of the disinfectant and the hygiene of the operator during the cleaning and disinfection. Wear personal protective equipment: ®

- Safety glasses.
- Protective gloves.
- Mouth and nose protective.



### ATTENTION

Incompatible cleaning agents!

The components of the Envelop System are made of thermoplastic polymers. Solvents can spoil synthetic material and coating. Strong acids or alkalis can cause embrittlement.

Cleaning the power unit, the mattress (with air cells) and the coverlet:

- Do not use hydrocarbon solvents, detergents containing alcohol or acids or alkalis.
- Do not use any abrasive cleaning materials.

Incompatible disinfectants

Cleaning the power unit, the mattress (with air cells) and the coverlet:

- Only use disinfectants without chlorides, halides.
- Do not use disinfectants containing gasoline, paint thinner, alkaline, acid, alcohol, or aldehyde (e.g. ethanol, propanol).

In order to avoid the embrittlement of thermoplastic materials:

- Do not use disinfectants containing alcohol.

## 8 Cleaning and Disinfection

### 8.1 Cleaning

When using the Envelop System in non-clinical areas the users or appropriately trained cleaning personnel can carry out the cleaning of the device.



#### WARNING

Remove the power cord set from the wall socket before cleaning of the power unit. Do not spray any cleaning liquid directly onto the power unit.

Cleaning of the power unit

#### Cleaning of the Surfaces of the Power Unit

- (1) Power off the power unit and unplug the power cord set from the socket.
- (2) Wet a soft cloth with water, mix it with commercially available washing-up liquid.
- (3) Wipe off dirt and dust accumulations.
- (4) Then dry the surfaces with a clean soft cloth.

Cleaning of the coverlet

#### Cleaning the Coverlet

The coverlet can be easily removed by derailing the zipper between coverlet and the mattress base. The cleaning of the coverlet can be done by using any of the available disinfectants at their usual concentration. At the end, rinse disinfectant off thoroughly with water and leave to dry. Avoid detergents containing phenols or other corrosive substances. Ensure that the mattress and the coverlet are dry before new use. The hygiene regulations of institution are to be followed in the institutional care environments.

- (1) Wet a soft cloth moderately with water, mix it with commercially available washing-up liquid. Wipe off dirt.
- (2) Wipe cleaned areas with soft dry cloth.
- (3) If heavily soiled the coverlet can be washed in the washing machine using commercially available detergent.
- (4) Washing temperature please follow the instruction on the washing care label.
- (5) Dry the coverlet thoroughly after washing. Make sure that no moisture remains in folds or creases.
- (6) Do not put the coverlet in the dryer or near sources of heat.

## 8 Cleaning and Disinfection

If the coverlet is soiled or loses its water-resistant properties, it must be replaced.

Any resulting damage of the mattress caused by a spoiled coverlet will be not covered by the warranty.

Please follow the hygiene control regulations of your local authority.



### **WARNING**

If the mattress coverlet is not securely fixed onto the mattress, the air cells and coverlet movement may be unstable and may cause ricks of patient injury.



### **ATTENTION**

Unpermitted after-treatment of the coverlet!

As a follow-up treatment of the coverlet:

- Do not bleach.
- Do not iron.
- Do not dry clean.

---

### **8.2 Disinfection**

Hygiene requirements of the operator

The operator must be notified about which measures apply to the Envelop System and the actual hygiene directives for disinfection. The disinfection of the Envelop System or parts of it can be performed only by trained personnel, who are familiar with the hygiene requirements of the institution.

Disinfection procedure

#### **Disinfection Procedures**

Please follow the procedure required by your local health authority.



### **CAUTION**

For repair, please contact your local distributor.

Please follow the hygiene control regulations of your local authority.

---

## 9 Care and Maintenance

### 9.1 Inspection

The safe operating condition of the Envelop System has to be checked at each use by the operator or during use by the patients and at least once in a year in particular with regards to the following:

- Function of the keys of the power unit.
- Function of the emergency CPR.
- Condition of the air hoses and quick coupling.
- Condition of the air cells.
- Condition of the coverlet.

### 9.2 Maintenance of Air Filter

The air filter should be cleaned regularly. It should be checked often, and depending on the usage environment may require to be changed often.

- (1) Power off the power unit and unplug the power cord set from the socket.
- (2) Remove air filter from the rear panel by opening the air filter cap and clean or replace with a new filter.

### 9.3 Maintenance of Battery Pack

- (1) Remove the battery pack from the power unit and store it separately.
- (2) Remove the battery pack from the power unit and well-packaged separately during transportation to prevent the battery pack damaged by shock and vibration.
- (3) The routine maintenance is required that the battery pack should be charged and checked the condition every 3 months.
- (4) Consider to replace the battery pack with the new Carilex standard battery pack if one of the following conditions is noted:
  - The battery pack has leaking fluids.
  - The wrapping film is damaged.
  - The battery pack appearance is swell or uneven.
  - The battery run time drops below 80% of the original run time.

# 10 Troubleshooting

Problem	Control Procedure	Possible Solution
1.) The power unit is working but the mattress is not inflating.	1.1) Verify that air flows liberally across the tubes and the mattress manifold. Check if there are any cuts, blockage or breakages.	1.1) It may be necessary to move the tubes or the manifold if they are kinked or twisted. In case of cuts or rips, replace the air cells or air hoses.
	1.2) Verify that the quick coupling is correctly connected to the air outlets of power unit.	1.2) Firmly connect the quick coupling.
	1.3) Verify that the CPR valve is correctly closed.	1.3) Firmly close the CPR valve.
2.) The patient sinks into the mattress.	2.1) Check the weight setting on the power unit.	2.1) Increase the patient's weight setting until the correct support pressure is achieved.
	2.2) Check for any abnormal air loss from the mattress.	2.2) Replace the components that are abnormally losing air with an authentic replacement part.
	2.3) Check the air filter.	2.3) Clean or replace the air filter.
	2.4) Verify that the CPR valve is closed correctly.	2.4) Firmly close the CPR valve.
3.) The power unit cannot power on.	3.1) Verify that the power cord set is plug into the proper socket.	3.1) Insert the power cord set of power unit into an appropriate socket and turn the power on.
	3.2) Verify that the power cord set is properly connected to the power unit.	3.2) Insert the power cord set into the power unit and turn the power on.
	3.3) Verify that the power cord set is not damaged.	3.3) Replace with a functioning power cord set.
	3.5) The power unit is not responding to the control procedures listed above.	3.5) Contact the authorized distributor for technical service.

# 11 Technical Data

**Power unit**

The Envelop System is suitable for continuous operation.

Model .....SR388  
 Dimensions(W x H x D).....37.5 x 32 x 18.5cm  
 Weight.....6Kg  
 Electrical Rating.....100-240Vac 50/60Hz 1.4A  
 Power Consumption.....Max. 60W (normal operation)  
 Fuse Rating.....T3.15A 250V  
 Electrical Classification .....Class I  
 Applied Part.....Type BF mattress  
 IP Code .....IP21  
 Rechargeable Li-Ion Battery Pack.....4S1P, type 59H0186-504-G,  
 rated 14.4Vdc 3Ah  
 Safety Certificate.....US NRTL\_SGS Q-Mark Listing  
 This system is not AP / APG protected.

EMC & Safety Certified Standard  
 Safety: IEC/EN 60601-1\_v3.1  
 AS/NZS IEC 60601.1: 2015  
 EMC: IEC/EN 60601-1-2\_v3.0

Operating Conditions  
 Temperature Range: 5°C to 40°C  
 Relative Humidity Range: 15% to 90%  
 Atmosphere Range: 700hPa to 1060hPa

**Mattress**

Min. Patient Weight .....30Kg  
 Max. Patient Weight for Standard Mattress .....300Kg  
 for Bariatric Mattress .....450Kg  
 Material of Air Cells.....Nylon with TPU lamination

The Envelop System must be decontaminated before disposal.  
 Disposal of old electrical and electronic equipment - valid in the  
 European Union: WEEE Directive 2012/19/EU.



This symbol on the product or on its packaging indicates that this product should not be treated as household waste. Instead, this product should be taken to the appropriate place of disposal for the recycling of electrical waste and electronic equipment.

# Declaration of Conformity

## For EN 60601-1-2

**Company Name:** Carilex Medical, Inc.

**Company Address:** No. 77, Keji 1st Rd., Guishan Dist., Taoyuan City (333), Taiwan (ROC)

**Trade Name:** Carilex

**Report Number:** ETC 16-05-RBO-041

**Power Supply:** Power Input: AC 100-240V, 50/60Hz 1.4A  
Battery pack input: 14.8Vdc or 14.4Vdc

<b>Recommended separation distances between portable and mobile RF communications equipment and the ME equipment</b>			
The Envelop_ Air Pump is intended for use in an electromagnetic environment in which radiated RF disturbances are controlled. The customer or the user of the Envelop_ Air Pump can help prevent electromagnetic interference by maintaining a minimum distance between portable and mobile RF communications equipment (transmitters) and the Envelop_ Air Pump as recommended below, according to the maximum output power of the communications equipment.			
Rated maximum output power of transmitter W	Separation distance according to frequency of transmitter m		
	150 kHz to 80 MHz	80 MHz to 800 MHz	800 MHz to 2.5 GHz
	$d = \left[ \frac{3.5}{P} \right] \sqrt{P}$	$d = \left[ \frac{3.5}{E_1} \right] \sqrt{P}$	$d = \left[ \frac{7}{E_1} \right] \sqrt{P}$
0.01	0.12	0.12	0.23
0.1	0.37	0.37	0.74
1	1.17	1.17	2.33
10	3.7	3.7	7.37
100	11.67	11.67	23.33

# 12 EMC Declaration

## Declaration – electromagnetic emissions and immunity – for EQUIPMENT and SYSTEMS that are not LIFE-SUPPORTING and are specified for use only in a shielded location

<b>The Envelop_ Air Pump declaration – electromagnetic immunity</b>			
The Envelop_ Air Pump system is intended for use in the electromagnetic environment specified below.			
The customer or the user of the Envelop_ Air Pump system should assure that it is used in such an environment.			
Immunity test	IEC 60601 test level	Compliance level	Electromagnetic environment - guidance
Conducted RF IEC 61000-4-6	3 Vrms 150 kHz to 80 MHz	3V	Portable and mobile RF communications equipment should be used no closer to any part of the EQUIPMENT or SYSTEM including cables, than the recommended separation distance calculated from the equation applicable to the frequency of the transmitter.  Interference may occur in the vicinity of equipment marked with the following symbol.  
Radiated RF IEC 61000-4-3	3 V/m 80 MHz to 2.5 GHz	3V/m	

### Declaration – electromagnetic immunity

The Envelop_ Air Pump system is intended for use in the electromagnetic environment specified below.			
The customer or the user of the Envelop_ Air Pump system should assure that it is used in such an environment.			
Immunity test	IEC 60601 test level	Compliance level	Electromagnetic environment - guidance
Electrostatic discharge (ESD) IEC 61000-4-2	±6 kV contact ±8 kV air	±6 kV contact ±8 kV air	Floors should be wood, concrete or ceramic tile. If floors are covered with synthetic material, the relative humidity should be at least 30 %.
Electrical fast transient/burst IEC 61000-4-4	±2 kV for power supply lines ±1 kV for input/output lines	±2 kV for power supply lines	Mains power quality should be that of a typical commercial or hospital environment.
Surge IEC 61000-4-5	±1 kV differential mode ±2 kV common mode	±1 kV differential mode ±2 kV common mode	Mains power quality should be that of a typical commercial or hospital environment.
Voltage dips, short interruptions and voltage variations on power supply input lines IEC 61000-4-11	<5 % UT (>95 % dip in UT) for 0.5 cycle 40 % UT (60 % dip in UT) for 5 cycles 70 % UT (30 % dip in UT) for 25 cycles <5 % UT (>95 % dip in UT) for 5 sec	<5 % UT (>95 % dip in UT) for 0.5 cycle 40 % UT (60 % dip in UT) for 5 cycles 70 % UT (30 % dip in UT) for 25 cycles <5 % UT (>95 % dip in UT) for 5 sec	Mains power quality should be that of a typical commercial or hospital environment. If the user of the EQUIPMENT or SYSTEM requires continued operation during power mains interruptions, it is recommended that the EQUIPMENT or SYSTEM be powered from an uninterruptible power supply or a battery.
Power frequency (50/60 Hz) magnetic field IEC 61000-4-8	3 A/m	3 A/m	Power frequency magnetic fields should be at levels characteristic of a typical location in a typical commercial or hospital environment.

### Declaration – electromagnetic emissions

The Envelop_ Air Pump is intended for use in the electromagnetic environment specified below. The customer or the user of the Envelop_ Air Pump should assure that it is used in such an environment.			
Emissions test	Compliance	Electromagnetic environment - guidance	
RF emissions CISPR 11	Group 1	The Envelop_ Air Pump uses RF energy only for its internal function. Therefore, its RF emissions are very low and are not likely to cause any interference in nearby electronic equipment.  The Envelop_ Air Pump is suitable for use in all establishments, including domestic establishments and those directly connected to the public low-voltage power supply network that supplies buildings used for domestic purposes.	
RF emissions CISPR 11	Class A		
Harmonic emissions IEC 61000-3-2	Class A		
Voltage fluctuations/ Flicker emissions IEC 61000-3-3	Complies		

## 12 Safety Precautions for Li-Ion Battery Pack

The safety precautions for Li-Ion battery pack are quoted from IEC 62133 Annex B & C. The following represents a typical, but non-exhaustive, list of good advice to be provided by the manufacturer of secondary cells and batteries to equipment manufacturers and battery assemblers.

- (1) Do not short-circuit a cell or battery. Do not store cells or batteries haphazardly in a box or drawer where they may short-circuit each other or be short-circuited by conductive materials.
- (2) Do not remove a cell or battery from its original packaging until required for use.
- (3) Do not expose cells or batteries to heat or fire. Avoid storage in direct sunlight.
- (4) Do not subject cells or batteries to mechanical shock.
- (5) In the event of a cell leaking, do not allow the liquid to come into contact with the skin or eyes. If contact has been made, wash the affected area with copious amounts of water and seek medical advice.
- (6) Seek medical advice immediately if a cell or battery has been swallowed.
- (7) Keep cells and batteries clean and dry.
- (8) Wipe the cell or battery terminals with a clean dry cloth if they become dirty.
- (9) After extended periods of storage, it may be necessary to charge and discharge the cells or batteries several times to obtain maximum performance.
- (10) Dispose of properly. When disposing of secondary cells or batteries, keep cells or batteries of different electrochemical systems separate from each other.
- (11) The Li-Ion Battery Pack should be charged at temperatures between 10°C and 40°C.
- (12) The Li-Ion Battery Pack should be discharged at temperatures between 10°C and 60°C.
- (13) Battery usage by children should be supervised.
- (14) Always purchase the battery recommended by the device manufacturer for the equipment.
- (15) Secondary cells and batteries need to be charged before use. Always use the Correct charger and refer to the manufacturer's instructions or equipment manual for proper charging instructions.
- (16) Retain the original product literature for future reference.
- (17) When possible, remove the battery from the equipment when not in use.

carilex<sup>®</sup>

---