



## Relief Turn Lateral Rotation Mattress

### User Manual



H&R Healthcare  
TEL: (732) 367-5533  
1750 Oak Street, Lakewood, NJ08701  
[www.handrhealthcare.com](http://www.handrhealthcare.com)



# CONTENTS

IMPORTANT SAFEGUARDS	2
PRODUCT SYMBOLS	4
INTRODUCTION	5
INTENDED USE	5
PRODUCT DESCRIPTION	5
PRODUCT INSTALLATION GUIDE	6
PANEL DISPLAY AND OPERATION GUIDE	8
WARNING CODE REFERENCE	14
CLEANING	15
STORAGE	16
MAINTENANCE	16
TROUBLESHOOTING	17
TECHNICAL DATA	18

## **IMPORTANT SAFEGUARDS**

### **READ ALL INSTRUCTIONS BEFORE OPERATING THIS DEVICE**



#### *NOTE, CAUTION AND WARNING STATEMENTS:*

NOTE – Indicate some tips.

CAUTION – Indicate correct operating or maintenance procedures in order to prevent damage to or destruction of the equipment or other property.

WARNING – Call attention to a potential danger that requires correct procedures or practices in order to prevent personal injury.



#### *WARNING– To reduce the risk of electrocution:*

1. Patients are not allowed to operate the product. Always unplug this product immediately while it's not in use.
2. Do not disassemble the Pump to avoid electrocution.
3. Do not place or store product where it can fall or be pulled into a tub or sink.
4. Do not place in or drop into water or other liquid. Do not use while bathing.
5. Do not reach for a product that has fallen into water. Unplug immediately.











#### *WARNING–To reduce the risk of burns, electrocution, fire or injury to person:*

1. The system must be operated with the mattress connected to the Pump. Please do not power-off or unplug the Pump while in use.
2. Always use the same voltage as stated on the label. Do not use other power cords on the Pump. Avoid children and pets acquire the plastic packing to prevent suffocation hazards.
3. Equipment is not suitable to use in the presence of a flammable anesthetic mixture with air or with oxygen or nitrous oxide.
4. Keep away from sharp objects.
5. Close supervision is necessary when this product is used by, on, or near children or people with disabilities.
6. Use this product only for its intended use as described in this manual. Do not use attachments not recommended by the manufacturer.
7. Never operate this product if the Pump has a damaged power cord or plug, if the Pump is not working properly, if the Pump has been dropped or damaged, or the Pump has been dropped into water. Return the product to a service center or to the distributor for examination and repair.
8. Keep the power cord away from heated surfaces.

9. Never block the air openings of this product or place the product on a soft surface, such as a bed or couch, where the openings may be blocked. Keep the air opening free of lint, hair, and other similar particles.
10. Never drop or insert any object into any air opening or hose tube.
11. Avoid dropping or putting any heavy object on the Pump.
12. Place the power cord and hose tube at patient's foot area to avoid strangling of patient's neck.
13. Avoid electromagnetic interference by not have strong electro-magnetic or RF generated equipment nearby patient's environment.
14. The Pump will have minor heat generated in operation, please do not direct contact the surface continuously for more than 1 minute.
15. When the mains supply is lost or had temporarily failed, the Pump will stop and the power failure alarm will alarm up to 20 minutes. This is normal and the product will return to normal operation once the mains supply is resumed.
16. Connect this product to a properly grounded outlet only. See Grounding Instruction.
17. Avoid the risk of electrocution by grounding the ground pin with grounding power outlet.
18. The connection of Lift-up detection to the PUMP shall be performed by the operator. It's not designed for patient to do the connection.

## Product Symbol Description

SYMBOLS	DESCRIPTION
I	POWER ON
O	POWER OFF
	ATTENTION
	“BF” SYMBOL, INDICATE THIS PRODUCT IS ACCORDING TO THE DEGREE OF PROTECTION AGAINST ELECTRIC SHOCK FOR TYPE BF EQUIPMENT, APPLIED PART:MATTRESS
	CAUTION, READ THE INSTRUTION BEFORE USE
	AWAY FROM THE FLAME
IP21	WATER AND DUST PROTECTION CLASSIFICAITON
	FUSE SPECIFICATION
	DISPOSAL OF ELECTRICAL & ELECTRONIC EQUIPMENT (WEEE): THIS PRODUCT SHOULD BE HANDED OVER TO AN APPLICABLE COLLECTION POINT FOR THE RECYCLING OF ELECTRICAL AND ELECTRONIC EQUIPMENT.
	UL CERTIFICATION LOGO (COMPLIACE WITH IEC60601-1) WITH RESPECT TO ELECTRICAL SHOCK, FIRE AND MECHANICAL HAZARDS ONLY IN ACCORDANCE WITH IEC60601-1.
	CB CERTIFICATION LOGO
	CE CERTIFICATION LOGO

## 1. INTRODUCTION

This manual provides the information required for the initial set up and for the normal operation of the **Relief Turn Air Mattress System**. Before operating the **Relief Turn Air Mattress System**, be sure the operator had read and understood in detail the content of this manual.

## 2. INTENDED USE

The **Relief Turn Air Mattress System** is intended to help and reduce the incidence of pressure ulcers while optimizing patient's comfort. The **Relief Turn Air Mattress System** may be used in a variety of settings including, but not limited to individual home care setting and long-term care of whom suffering from pressure ulcer, or pain management as prescribed by physician.



NOTE: Equipment is not suitable for use in the presence of a flammable anesthetic mixture with air or with oxygen or nitrous oxide.

## 3. PRODUCT DESCRIPTION

The **Relief Turn Air Mattress System** is a lateral rotation replacement system used in the prevention and relief for patients with, or vulnerable to, pressure ulcers.

The Control Unit of the **Relief Turn Air Mattress System** is a Pump featuring a digital pressure adjustment function, mode selections, and audiovisual alarms. The mattress has a heavy-duty polyester base sheet with a vapor permeable two-way stretched polyester cover sheet.

Lateral rotation turning function is achieved by using special designed lateral rotation turning air cells to achieve the nursing needs. The orientation of turning is defined by patient's orientation. Single turn mode can either maintain the turning level constantly or alternate between turning and non-turning level. Full turn mode will alternate between left turn, horizontal level, right turn, and horizontal level periodically.

## PRODUCT INSTALLATION GUIDE

### How to Start

1. Remove the existing mattress from the bed frame.
2. Replace the standard mattress with LAL Turning Mattress, making sure to position the mattress with the air hoses at the foot of the bed.
3. Secure the tie down straps beneath the mattress to the bed frame.
4. Hang the Master Control Unit on the foot-board of the bed frame using the retractable hanging brackets. Attach the air hoses to the outlet plate located on the left side of the Master Control Unit. Be sure to match the colors on the air hoses to the colors on the outlet plate.
5. Carefully plug power cord into the power side plate located on the right side of the Master Control unit, and then to a properly grounded outlet.
6. Turn power switch to on position, also located on power side plate.

### Set Up Side Bolster Rolls

**Side Bolster Rails:** On both sides of the mattress are 2 Air Side Bolster Rails that come up above the surface of the mattress to help encase the patient during the lateral rotation process. If the patient needs to be transferred in or out of bed, those Air Rails can be disconnected and the air evacuated. Locate the first zippered compartment in the purple base cover and unzip from foot end to middle of mattress. Inside you will see a hose with a red-check-valve, connected to a clear port on the Side Bolster Rail, (see figures below). Press the gray button to disconnect the hose and reconnect to the blue port, which is a vent only. Push as much air out of the Bolster Rail as you can, and you will have full access to the normal 9 inch high surface.



1. Position the Pump by its elastic hanger brackets over footboard of the bed. The elastic hanger brackets will self-adjust onto the footboard tightly.

Connect two 3 hose color connectors to match the colored side panel

2. Connect the power cord to the Pump. The power switch should remain off.

3. Press the red power cord protector downward to secure the power cord.

4. Plug the power cord into the electrical outlet.

ffi NOTE: Check and ensure the Pump unit is suitable for the local power voltage.

ffi CAUTION: The Pump can only be applied to the mattress recommended by the manufacturer. Do not use the Pump for any other purpose.

ffi WARNING: Do not place the Pump unit in area where power cord can come off easily.

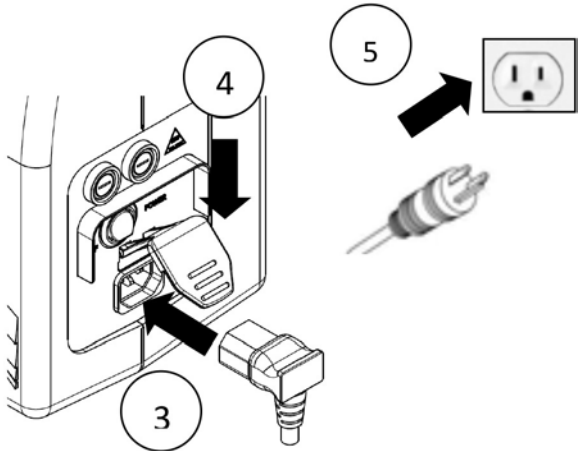

## PANEL DISPLAY AND OPERATION GUIDE

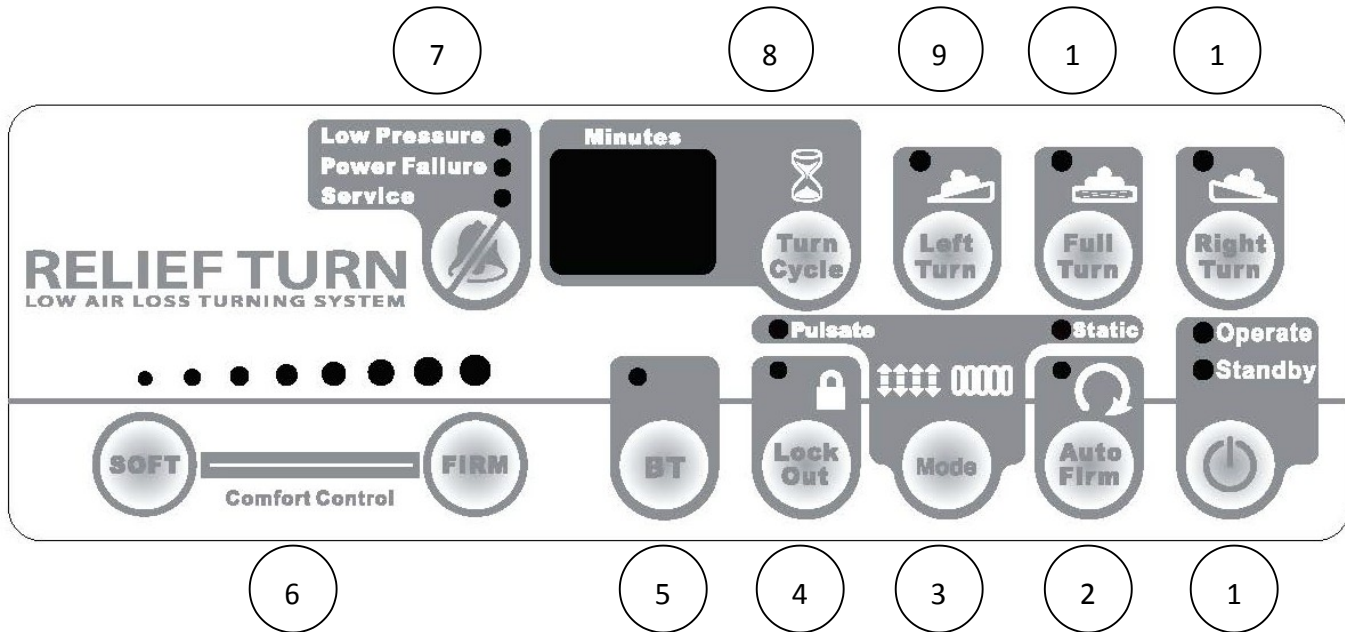

### 3.1 PANEL DISPLAY

- ① Operate or Standby
- ② Auto Firm
- ③ Function Mode (Static and Pulsate)
- ④ Panel Lock-out
- ⑤ Big Turn
- ⑥ Comfort Control (Soft and Firm)
- ⑦ Alarm Mute and Alarm Indicator
  - Low Pressure Alarm Indicator
  - Power Failure Alarm Indicator
  - Service (Malfunction) Alarm Indicator
- ⑧ Turning Cycle Time (Minutes) or Warning Code Display
- ⑨ Left Turn
- ⑩ Full Turn
- ⑪ Right Turn

#### 3.1.1 Operate or Standby



Press this button to start operating or go into standby.

#### 3.1.2 Auto-Firm



The Pump will go into the inflation mode (LED lights flashing) every time the operate mode is triggered. This insures the mattress to be able to reach its maximum operating pressure. Once the max pressure level is reached, the pump

will automatically switch into the previous selected mode and comfort level. User can also use this function as full mattress inflation during patient sit-up or ingress/egress for better support.



### 3.1.3 Function Mode (Static)

- Static—the mattress maintains at 50% of the selected pressure in alternate mode.
- Pulsate – Every 5 minutes the system drops 40% pressure to the air bladders creating pressure redistribution



### 3.1.4 Panel Lock-Out

Press the Lock-Out button to lock the panel. Should the panel remain untouched for 30 seconds, the Lock-Out feature will lock the panel to prevent changing settings without authorization. To unlock, hold the Lock-Out button down until the lock-out light disappears.



### 3.1.5 Big Turn

Press the Big Turn button to achieve higher turning angles.



### 3.1.6 Comfort Level

Comfort level controls the air pressure output level. Press Firm button and the output pressure will increase and higher pressure output will support heavier weight patient, for decreasing air pressure, vice versa.



### 3.1.7 ALARM MUTE

Press the alarm mute button to suspend temporarily alarms. Should the situation not resolved and fault conditions continue, the alarm will resume notifying the patient and caregiver.



### 3.1.8 Turning Cycle Time (Minutes) Adjustment

- Single Turn (left or right turn): Press Turn Cycle to active periodic single turn.
- Full Turn (left and right turn alternatively): always periodic.
- Select turning time from 5-95 minutes by pressing the Turn Cycle button (the display time represents the continuing time for each turning position.)
- Hold the button for 3 seconds to reset the shortest turning time, 5 minutes.



### 3.1.9 Left Turn

Initiate or cancel Left Turn function by pressing this button.



### 3.1.10 Full Turn

Initiate or cancel Full Turn function by pressing this button.



### 3.1.11 Right Turn

Initiate or cancel Right Turn function by pressing this button.

## 3.2 OPERATION GUIDE

### 3.2.1 General Operation:

 **NOTE:**  The power switch is located on the side of the Pump.

- Press  to turn on the unit, all LED indicators on the control panel will light up accompanied with a beep for 2 seconds (check for indicator failure if any), and the indicator of Standby on the control panel will light up. If the Pump was previously shut off in operate mode then the Pump will enter operate mode directly.

P.S. To test the battery, press  to turn off the power and the power failure alarm should be triggered. Refer to **5.2.3 Audiovisual Alarm** if the alarm is not triggered.



- Press the Operate button  and the system will begin to inflate and the

"Auto-Firm" indicator will be flashing.

I The mattress should be fully inflated within 20 minutes, and automatically enter the previous operating mode, otherwise the low pressure alarm with warning code "L.P." will be triggered.





Note: Do not proceed to other settings before inflation is completed.



- After initial inflation is completed. Press Auto-Firm button  for moving the patient onto the mattress. The mattress will turn into a steady condition in around 5 minutes. Move the patient onto the mattress and press Auto-Firm button  again to cancel Auto-Firm mode and select the appropriate mode.
- According to the weight of the patient, adjust the pressure setting to the most suitable level without "bottoming-out". User can determine an appropriate pressure by adjusting the Comfort Level. Please consult with your physician for a proper setting.



Warning: the Pump unit should always be operating to prevent bedsores occurring.

- In operate mode, press operate/standby button  for the system to enter standby mode. The system should be in standby mode before shut down. Switch the power switch  to off and the warning code "S.d" will appear on the display to shut off the system.



Note: For reminding purpose, power failure alarm will be triggered if the power is switched off in operating mode (refer to **5.2.3 Audiovisual Alarm**). Press power switch  to restart the system, or press Alarm Mute  to turn off the system (refer **5.2.4 Alarm Mute**).

**Table 1 Weight and Comfort Level Reference**

**36" MATTRESS**

Light 1	Light 2	Light 3	Light 4	Light 5	Light 6	Light 7	Light 8
90-130	120-175	160-225	200-295	285-395	375-475	450-575	550-650

**42" MATTRESS**

Light 1	Light 2	Light 3	Light 4	Light 5	Light 6	Light 7	Light 8
150-200	200-250	250-350	350-400	400-450	440-550	550-650	650-750

**48" MATTRESS**

Light 1	Light 2	Light 3	Light 4	Light 5	Light 6	Light 7	Light 8
200-300	300-350	350-450	450-550	550-650	650-750	750-875	875-1000

**3.2.2 CPR**

- When CPR needs to be performed, quickly disconnect the hose connectors from the Pump, and disconnect the side bolsters as well.

**3.2.3 Audiovisual Alarm**

- Power Failure—When electrical shortage occurred or power cord is unplugged without turning off the Pump or  is pressed (intentionally or unintentionally), the "Power Failure" indicator will light up along with buzzer and will last 20 minutes.

 *NOTE: When the Pump has not been used for more than 3 months, the Pump may need 6 hours or more of operating time for the alarms to function properly.*













- Low Pressure—When an abnormal low pressure occurred in body section for 10 seconds after the pressure is below the abnormal pressure threshold, the "Low Pressure" indicator will flash and beep. Should the situation not resolved and fault conditions continue, the alarm will resume.
- Service (Malfunction) —When fault conditions occur, the "Service" indicator will light up along with buzzer.

 *Note: Refer to **Table 2 for Warning Code Reference Table** if error code appears on the display or refer to **10. TROUBLESHOOTING**.*

### 3.2.4 Alarm Mute

- When alarms are triggered, both LED light and buzzer will turn on to warn the patient and caregiver. By pressing the button, it will temporarily mute the buzzer so the caregiver may check for possible causes. Should the situation not be resolved and fault conditions continue, the alarm will resume. Refer to **10. TROUBLESHOOTING** for diagnosis.
- During “power failure”, pressing “alarm mute” will cease all buzzers and indicators and turn off the system.
- During “low pressure alarm” if the pressure resumes back to normal then the low pressure alarm will stop.
- When more than one alarm is triggered, the alarm will be performed according to priority level. Refer to **Table 2 Warning Code Reference Table** for priority level.

**Table 2 Warning Code Reference**

PRIORITY HIHG ↓ LOW	WARNING CODE	INDICATOR LED	AUDIBLE OUTPUT MODE	CONDITION OF OUTPUT	WARNING DESCRIPTION	REMARKS
0	N/A	N/A	ONCE	Not in System Shutdown	Key Tone	Key Tone from Functional Button
1		Power Failure	ONCE	POWER-OFF	System Shutdown	Shutdown
2		ALLLED	ONCE	OPERATE OR STANDBY	Power-On	All Indicators Light On
3	N/A	N/A	ONCE	OPERATE OR STANDBY	State/Mode Switching	No Display
4		Auto Firm	ONCE	OPERATE	Mattress Inflation Completion	Inflation Ended
5		Auto Firm	ONCE	OPERATE	Auto-Firm Completion	Auto-Firm Ended
6	N/A	Power Failure	REPEAT (Cycle 4 sec.)	POWER-OFF	Power Failure Alarm	No Display
7		Low Pressure	REPEAT (Cycle 4 sec.)	OPERATE OR STANDBY	Power-On Inflation Failure Alarm	Inflate Failure
8		Low Pressure	REPEAT (Cycle 4 sec.)	OPERATE OR STANDBY	Auto-Firm Failure Alarm	Auto-Firm Failure
9		Low Pressure	REPEAT (Cycle 4 sec.)	OPERATE OR STANDBY	Low Pressure Overtime Alarm	Low Pressure
10		Service	REPEAT (Cycle 4.5 sec.)	OPERATE OR STANDBY	High Pressure Overtime Alarm	High Pressure
11		Service	REPEAT (Cycle 4.5 sec.)	OPERATE OR STANDBY	High Ambient Temperature Alarm	High Temperature
12		Service	REPEAT (Cycle 4.5 sec.)	OPERATE OR STANDBY	Air Valve 1 Positioning Failure Alarm	Air Valve 1 failure
13		Service	REPEAT (cycle 4.5sec.)	OPERATE OR STANDBY	Air Valve 2 Positioning Failure Alarm	Air Valve 2 failure
14		Service	REPEAT (Cycle 15 sec.)	OPERATE OR STANDBY	Battery Low Alarm	Battery would need to be replaced
15		NONE	NONE	FACTORY CALIBRATION MODE	Calibration Not Completed	Calibration Unfinished
16		NONE	NONE	FACTORY CALIBRATION MODE	Calibration Completed	Calibration Completed

## 6. CLEANING

Wipe the Pump unit with a damp cloth pre-soaked with a mild detergent, and keep the Pump unit away from dust. If other detergent is used, choose one that will have no chemical effects on the surface of the plastics case of the Pump unit.



**CAUTION:** Do not immerse or soak the Pump unit.

Clean the mattress cover by using single use wipes with a solution of neutral detergent and hand hot water. Rinse thoroughly with clean water and damp dry the mattress using single use wipes.

### **Disinfecting the cover**

If the cover is heavily soiled or has been exposed to bodily fluids such as blood, it will require a more thorough cleaning procedure.

Use single use wipes with a 0.1% chlorine solution (1,000ppm) and cold water to wipe the cover. If the cover requires heavier cleaning, use a 1% chlorine solution (10,000ppm) and cold water to wipe the cover. Rinse thoroughly with clean water and damp dry the mattress using single use wipes. Ensure the cover is completely dried before refitting to the mattress.

Frequent or prolonged exposure to higher concentration disinfectant solutions may prematurely age the fabric cover of mattresses. Cover surfaces should be protected during use and rinsed and dried thoroughly after disinfectant.

### **Laundering**

- Before laundering, mattress cover should be completely removed.
- Remove Lift-Up Detection Sensor located on the bottom base before laundering.
- Mattress covers can be laundered as following:
  - Prewash 60°C+15 minutes
  - Main wash 60°C+15 minutes
- This should be followed by a cold rinse and extraction.

### **Drying**

Mattress covers should be hung from a line or bar and drip dried in a clean indoor environment. Covers must be completely dried before refitting to the mattress.

Mattress covers can be tumble dried on a low heat setting for 90 minutes. Drying temperature must not exceed 40°C. Exceeding the temperature can cause significant damage to the mattress cover.

 **CAUTION:** Do not use phenolic-based product for cleaning.

 **CAUTION:** After cleaning, dry the mattress without direct exposure of sunlight.

## STORAGE

- To quickly vacuum air out from mattress for storage, rotate the CPR valve to OPEN position and disconnect the hose connector to release the air.
- Lay the mattress out flat and upside down.
- Roll from the head end towards the foot end.
- Packing strap can then be stretched around the rolled mattress to prevent unrolling.
- The power cord could be wrapped around the Pump bumper or disconnected for storage.

## 1. MAINTENANCE

### General

- Check main power cord and plug if there are abrasions or excessive wears.
- Check mattress cover for signs of wear or damage. Ensure mattress cover and tubes are stubbed together correctly.
- Check the air hoses for any kink or break. For replacement, please contact your local dealers.

### Fuse replacement

- Disconnect the plug from mains power when a blown fuse is suspected.
- Remove the cover of the fuse holder by means of a small screwdriver.
- Insert a new fuse of the correct rating in, and replace the cover of the fuse holder back. The fuse rating should comply with the requested specification.

### Air Filter Replacement

After checking **10. TROUBLESHOOTING**, if the air filter needs to be replaced:

- Replace the air filter located at the back of the Pump.
- The filter is reusable and can be washed gently with a mild detergent and water. Dry the filter before use.
- Check and replace air filter regularly if environment is dirty.

## 2. THE DISPOSAL OF AIR MATTRESS

When the air mattress is broken or no longer be useable, the mattress and the Pump may be discarded for recycle.

### 3. TROUBLESHOOTING

PROBLEM	SOLUTION
The mattress is not able to connect with the Pump	<ul style="list-style-type: none"> <li>■ Check if the mattress model (model no. located inside the cover by the foot end) xxAAAx matches with the Pump model xxBBB-xxx. The AAA should be the same as BBB. If not, please contact with the agent or distributor.</li> <li>■ Check if the Transport Cap is removed and make sure the connector is not broken.</li> </ul>
The Pump is showing no indications of working	<ul style="list-style-type: none"> <li>■ Check if the plug is connected to the mains supply.</li> <li>■ Check if the power switch is switched to ON position (press ).</li> <li>■ Check if there is any blown fuse.</li> </ul>
Power failure alarm failed	<ul style="list-style-type: none"> <li>■ If the Pump is in operation but failed to trigger the power failure alarm during power off. Charge the Pump for 6 hours or more of operating time and if the power failure still not works then please contact the dealer or agent for further investigation.</li> </ul>
The low pressure light is constantly flashing and the alarm is sounded	<ul style="list-style-type: none"> <li>■ Check if the CPR is at CLOSE position</li> <li>■ Check if the connection between air tubes to Pump unit is tightly secured.</li> <li>■ Check if all coupling connections along mattress are secured.</li> <li>■ If the mains supply is normal but there is no sound of the Pump, please remove the connector from the Pump to check if there's air comes out. If not, please turn off the machine and contact the dealer or agent for further investigation.</li> <li>■ If all of above steps have been checked. Press "Alarm Mute" for system to be verified again.</li> </ul>
The Pump is on but the mattress is not alternated	<ul style="list-style-type: none"> <li>■ Ensure the mattress inflation is completed.</li> <li>■ Check the Pump control panel the indicator of "Alternate" should be lighted on, if not, switch it to "Alternate."</li> <li>■ Check if "Service" alarm indicator is on with buzzer, if yes, contact the dealer or agent for further investigation.</li> </ul>
Service (Malfunction) Alarm is on	<ul style="list-style-type: none"> <li>■ Press "alarm mute" for system to be verified again. If the alarm is still on, please contact dealer or agent.</li> </ul>
The Pump is operating noisily	<ul style="list-style-type: none"> <li>■ Make sure the Pump is resting against a solid surface.</li> <li>■ If the noise is getting louder, contact the dealer or agent for further investigation.</li> </ul>
Patient is bottoming out (without alarm triggered)	<ul style="list-style-type: none"> <li>■ Pressure setting might be inadequate for the patient, adjust comfort level to FIRM (refer to <b>Table 1 Weight and Comfort Level Reference Table</b>) and wait for a few minutes for better comfort.</li> <li>■ Follow the procedures "The low pressure light is constantly flashing and the alarm is sounded" for inspection.</li> </ul>

If the above information does not solve the problem, please contact your local dealer or agent for further support.

#### 4. TECHNICAL DATA

##### Product Specification

Pump Unit		Air Mattress	
Model	9800/9842/9848	Model	9" Air Mattress
Dimension (in)	16(L)x 7(W)x 11(H)	Dimension (in)	80(L)x 35.5(W)x 8(H)
Weight (lbs)	14	Weight (lb)	26
Turn Cycle Time (mins)	5—95	No. of Air Cell	18 cells
Auto Firm Time (minutes)	20		
Pump output flow range (LPM)	1800L	Cell Material	TPU
Pressure Range (mmHg)	15—50 (±5)		
Power	AC120V 60Hz	Cover Material	Two-Way Stretched Polyester
Current	4.8 A <sub>MAX</sub> (@132V~)	Bottom Material	Polyester-PU
Fuse Rating	T5A 250VAC		
Classification	Class I (MOOP)	Standard Max. Weight(lbs)	350
	Type BF  (MOPP)	Bariatric Max. Weight(lbs)	1000
Warranty	1 year	Warranty	1 year